

I. FRAME & MISCELLANEOUS COVER COMPONENTS
 頭部・外装関係

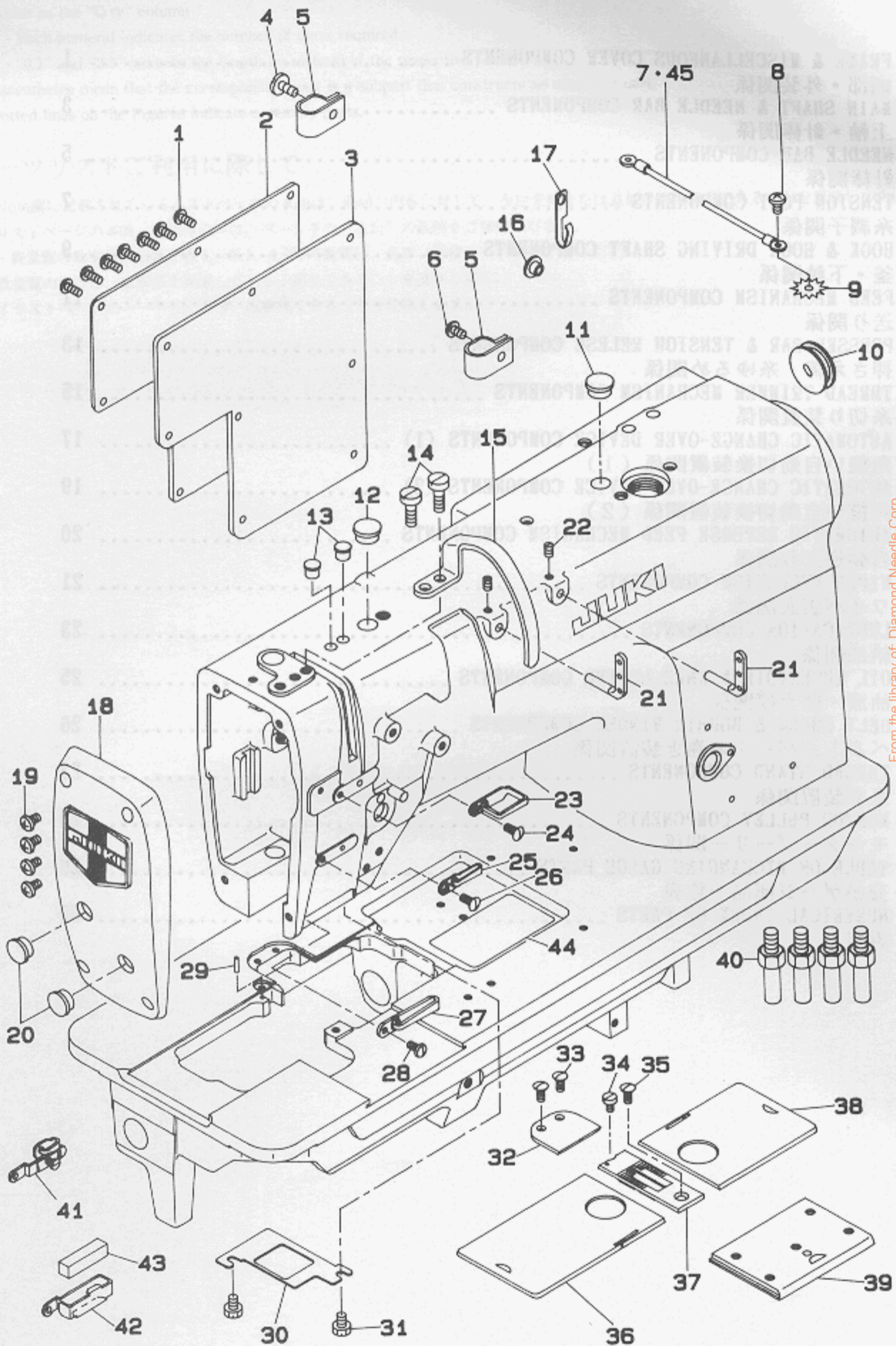

From the library of: Diamond Needle Corp

REF.NO	NOTE	PART NO.	DESCRIPTION	ヒンメイ	Qty
1		SS-4110815-SP	SCREW 11/64-40 L=8	ナメネジ 11/64-40 L=8	7
2		106-02902	SLIDE PLATE	マトイタ	1
3		101-01004	GASKET	マトイタハツキン	1
4		SS-6111140-SP	SCREW 11/64-40 L=11	ヒラネジ 11/64-40 L=11	1
5		D2112-555-B00	CORD HOLDER, LARGE	コートトメカナク A	2
6		SS-4120615-SP	SCREW 3/16-28 L=6	ナメネジ 3/16-28 L=6	1
7	#02	110-44054	GROUND WIRE ASM.	アスコート クミ	1
8		SS-4120615-SP	SCREW 3/16-28 L=6	ナメネジ 3/16-28 L=6	1
9		WT-0530002-KS	TOOTHED WASHER	ハツキサカネ A5.3	1
10		102-01200	RUBBER PLUG	オートシクアナ キャツブ	1
11		TA-1250504-R0	RUBBER PLUG	トメセン	1
12		TA-1270502-R0	RUBBER PLUG	トメセン	1
13		TA-0750704-R0	RUBBER PLUG	トメセン	2
14		SS-6151780-SP	SCREW 15/64-28 L=17.0	ヒラネジ 15/64-28 L=17	2
15		226-02007	THREAD TAKE-UP LEVER OIL GUARD	デンヒンカハ(コカマ)	1
16		TA-1250504-R0	RUBBER PLUG	トメセン	1
17	#04	135-30209	LUBRICATING OIL WICK STOPPER	キユウユシントメ	1
18		226-80250	FACE PLATE ASM.	メンイタ(カタハリ)クミ	1
19		SS-4121015-SP	SCREW 3/16-28 L=10	ナメネジ 3/16-28 L=10	4
20		TA-1250406-R0	RUBBER PLUG	トメセン D=12.5 L=4	2
21		110-18702	THREE-HOLE THREAD EYELET	ミツメイトカケ	2
22		SS-8120740-SP	SCREW 3/16-28 L=7	トメネジ 3/16-28 L=7	2
23		226-03005	THREAD GUIDE	イトアンナイ(ウイ)	1
24		SS-2090710-SP	SCREW 9/64-40 L=7	マルサラネジ 9/64-40 L=7	1
25		226-03104	THREAD GUIDE	イトアンナイ(ナカ)	1
26		SS-2090810-SP	SCREW 9/64-40 L= 7.5	マルサラネジ 9/40 L=7.5	1
27		B1131-057-000	FRAME THREAD GUIDE, LOWER	イトアンナイ シタ	1
28		SS-5090610-SP	SCREW 9/64-40 L=6	トラスネジ 9/64-40 L=6	1
29		B1104-051-000	THROAT PLATE PIN	ハリイタ トメピン	1
30		226-80003	PLATE	アゴブアチイタ(カタハリツキ)	1
31		SS-9110460-CP	SCREW 11/64-40 L=4	ロツカクホルト 11/64-40 L=4	2
32		226-02106	AUXILIARY COVER	ホシヨカハ	1
33		SS-2090710-SP	SCREW 9/64-40 L=7	マルサラネジ 9/64-40 L=7	2
34		SS-6090630-SP	SCREW 9/64-40 L=6	ヒラネジ 9/64-40 L=6	1
35		SS-2110920-TP	SCREW 11/64-40 L=8.5	マルサラネジ 11/64-40 L=8.5	1
36	#03	226-50857	BED SLIDE LEFT, ASM., A	イトキリスハリイタ(ヒタリ) Aクミ	1
37	#03	226-60609	THROAT PLATE 1/4	イトキリハリイタ(1/4")	1
38	#03	226-50352	BED SLIDE RIGHT, ASM., A	イトキリスハリイタ(ミキ) Aクミ	1
39		226-50055	BED SLIDE ASM.	スハリイタ(マエ)クミ(イトキリツキ)	1
40		226-02601	BED SCREW STUD	ハットシチュウ	4
41	#05	226-51459	THREAD GUIDE ASM., E	イトアンナイE(クミ)ハリイタオキ	1
42	#06	226-03609	THREAD GUIDE	フイルト イトアンナイ	1
43	#06	226-03708	FELT	フイルト	1
44		226-03807	LABEL	カマキユウユシラハル	1
45	#01	107-41759	GROUND WIRE ASM.	ケラントセンクミ	1

Note (注記) #01...FOR LH-3162-4
 #02...FOR LH-3162-7
 #03...EXCHANGING GAUGE PART
 (SEE P.29)
 #04...FOR -WB, -WO, -OB
 #05...OPTIONAL PART
 #06...FOR THE DESTINATION

LH-3162-4 用
 LH-3162-7 用
 交換ゲージ部品
 (29 ページご参照下さい。)
 -WB, -WO, -OB 用
 オプション対応
 仕向地用

2. MAIN SHAFT & NEEDLE BAR COMPONENTS
 上軸・針棒関係

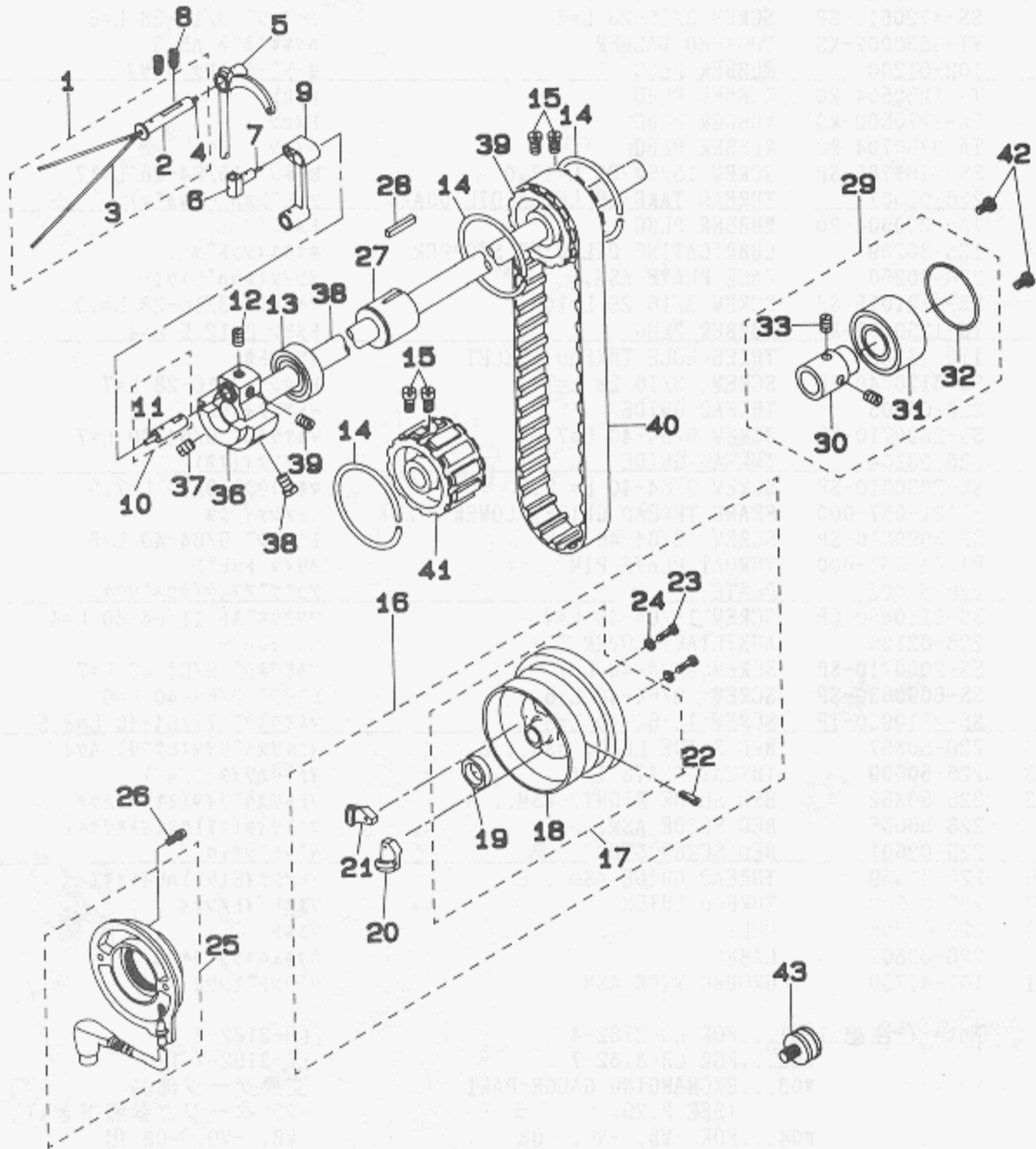

From the library of: Diamond Needle Corp

REF.NO	NOTE	PART NO.	DESCRIPTION	ヒンメイ	Qty
1		226-05158	THREAD TAKE-UP LEVER PIN ASM.	デンヒン 軸取上げピン(クミ)	1
2		226-05109	THREAD TAKE-UP LEVER PIN	デンヒン軸取上げピン	(1)
3		CQ-2020000-00	OIL WICK	エジン	(0.31)
4		CQ-2520000-00	OIL WICK	エジン	(0.04)
5		226-92909	THREAD TAKE-UP LEVER	デンヒン(コカマ)イトキリ	1
6		226-05208	TAKE-UP LEVER THRUST PIN	デンヒンスライトピン	1
7		CQ-2520000-00	OIL WICK	エジン	0.03
8		SS-8151150-TP	SCREW 15/64-28 L=10.5	トメネジ 15/64-28 L=10.5	2
9		226-84609	NEEDLE BAR CRANK ROD	ハリボウクランクロッド(カタハリツキ)	1
10		226-80656	NEEDLE BAR CRANK PIN ASM.	ハリボウクランクピン(カタハリツキ)クミ	1
11		CQ-5050000-00	OIL WICK	エジン	(0.1)
12		SS-8680540-SP	SCREW 9/32-28 L= 4.5	トメネジ 9/32-28 L=4.5	1
13		B1202-512-000	MAIN SHAFT BUSHING, FRONT	ウワシク マイハアリンク	1
14		B1214-019-000	SPROCKET RING	スプロケット リング	3
15		SS-6661110-SP	SCREW 1/4-40 L=11	ヒラネジ 1/4-40 L=11	4
16	#02	226-51566	HAND WHEEL ASM.	ハズミクマ(クミ)イトキリ	1
17	#02	226-51558	HAND WHEEL	ハズミクマ(ケツコウ)イトキリ	(1)
18		226-51509	HAND WHEEL	ハズミクマ(イトキリ)	(1)
19	#02	M4002-110-000	GENERATOR ROTOR	ハツデンキローター	(1)
20	#02	M4007-110-0AA	MAGNET FITTING BASE A ASM.	マグネット トリツケタイ A クミ	(1)
21	#02	M4007-110-0AB	MAGNET FITTING BASE B ASM.	マグネット トリツケタイ B クミ	(1)
22		SS-8151550-SP	SCREW 15/64-28 L=15	トメネジ 15/64-28 L=15	(2)
23	#02	SS-6111210-SP	SCREW 11/64-40 L=12	ヒラネジ 11/64-40 L=12	(2)
24	#02	WP-0450801-SD	WASHER 4.5X10.0X0.8	ヒラサガネ 4.5X10X0.8	(2)
25	#02	110-32265	GENERATOR STARTER ASM.	ハツデンキ スターター クミ	1
26	#02	106-04809	SCREW	ハツデンキ スターター トメネジ	2
27		226-04706	MAIN SHAFT BUSHING, CENTER	ウワシクナカメタル	1
28		226-04805	FELT	ウワシクナカメタルフェルト	1
29		226-04656	THRUST COLLAR ASM.	ウワシクスラストウケ(クミ)	1
30		226-04607	THRUST COLLAR	ウワシクスラストウケ	(1)
31		SB-1200001-00	BEARING D=20X47	ボールベアリング D=20X47	(1)
32		RO-4372002-00	RUBBER RING	Oリング	(1)
33		SS-8660530-TP	SCREW 1/4-40 L= 4.5	トメネジ 1/4-40 L=4.5	(2)
34		226-04409	COUNTERWEIGHT	ツリアイス	1
35		SS-8681650-TP	SCREW 9/32-28 L=16	トメネジ 9/32-28 L=16	1
36		SS-7681750-TP	SCREW 9/32-28 L=16.5	マルヒラネジ 9/32-28 L=16.5	1
37		SS-8680810-TP	SCREW 9/32-28 L=8.0	トメネジ 9/32-28 L=8	1
38		226-04003	MAIN SHAFT	ウワシク	1
39		226-04102	SPROCKET WHEEL	ウエスプロケット	1
40		226-04300	TIMING BELT	タイミングベルト	1
41		226-51608	SPROCKET WHEEL	シタスプロケット(マル14.72)	1
42		SS-7120760-SP	SCREW 3/16-28 L= 7.0	マルヒラネジ 3/16-28 L=7	2
43	#01	226-22401	SYNCHRO FRANGE	シンクロフランジ	1

Note (注記) #01...FOR LH-3162-4

#02...FOR LH-3162-7

LH-3162-4 用

LH-3162-7 用

3. NEEDLE BAR COMPONENTS 針棒関係

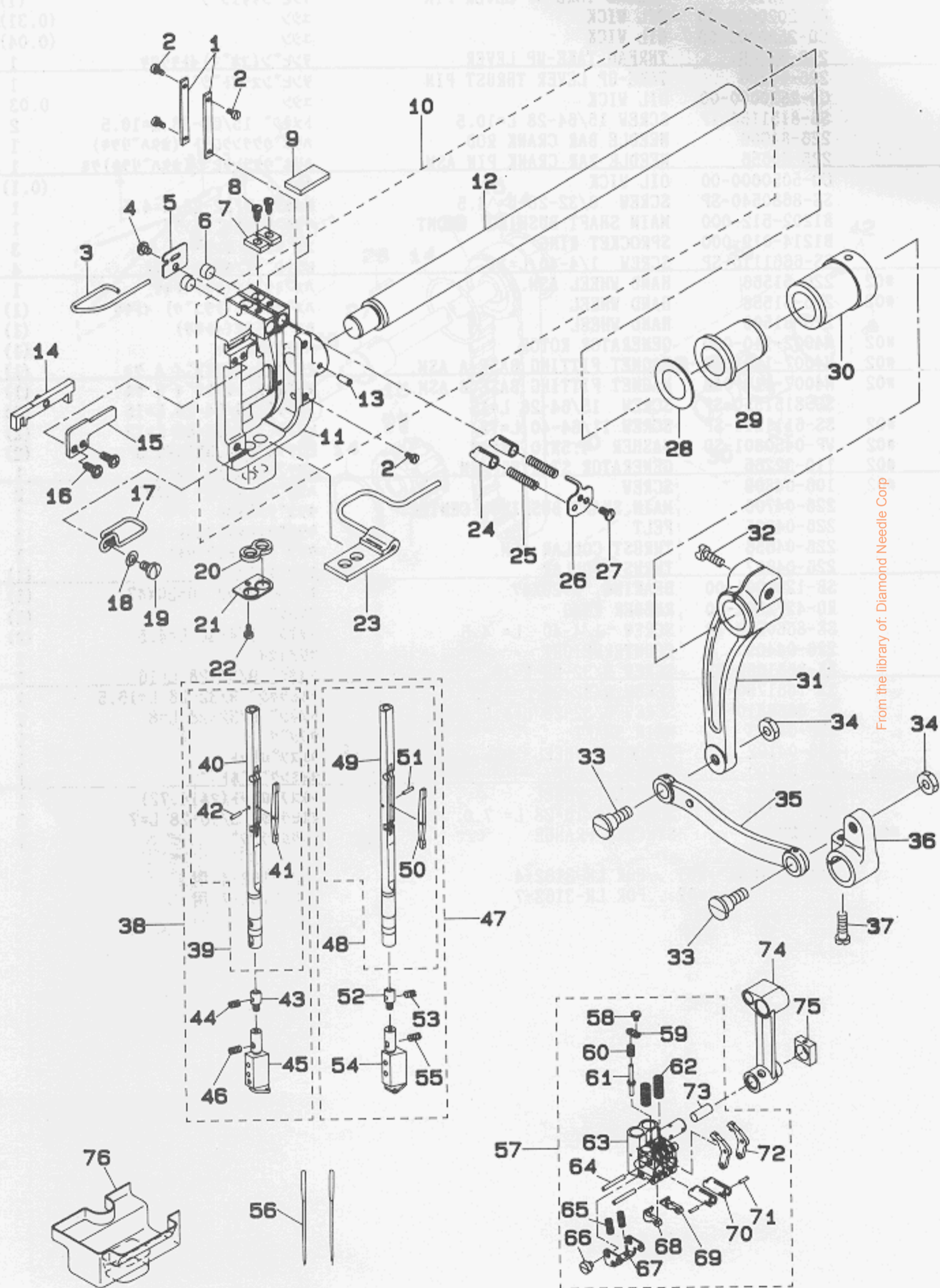

From the library of: Diamond Needle Corp

REF. NO	NOTE	PART NO.	DESCRIPTION	ヒンメイ	Qty
1		226-81100	NEEDLE BAR GUIDE PLATE	ハリホウアンナイハシ(カタハリツキ)	2
2		SS-6060510-TP	SCREW 3/32-56 L=4.5	ヒラネジ 3/32-56 L=4.5	4
3		CQ-2020000-00	OIL WICK	エジン	0.1
4		SS-4090415-SP	SCREW 9/64-40 L=4	ナハネジ 9/64-40 L=4	1
5		226-81209	FELT COVER	フェルトオサエ	1
6		110-02904	ROLLER FELT	メンブユリヨウチヨウセツフイルト	2
7		226-81605	NEEDLE BAR SWIVEL STOPPER	ハリホウマワリトメ	2
8		226-81704	STOPPER SCREW	ハリホウマワリトメメネジ	2
9		B1422-512-000	FELT	ハリホウヨトメナイフイルト	1
10		226-81050	NEEDLE BAR FRAME ASM.	ハリホウヨウトウタヱ(カタハリツキ)ケ	1
11		226-81001	NEEDLE BAR FRAME	ハリホウヨウトウタヱ(カタハリツキ)	(1)
12		226-06602	NEEDLE BAR SHAFT	ハリホウヨウトウジク	(1)
13		PT-0502700-S0	TAPERED PIN	テールピン	(1)
14	#01	226-82157	SLIDE BLOCK	スベリコ(クミ)C	1
15		226-81803	SLIDE BLOCK GUIDE PLATE	スベリコアンナイハシ	1
16		SS-4090815-SP	SCREW 9/64-40 L=8	ナハネジ 9/64-40 L=8	2
17		226-85903	FELT GUIDE	ハリホウユホウフェルトガイ	1
18		WP-0450000-SD	WASHER 4.5X8X0.5	ヒラネジ 4.5X8X0.5	1
19		SS-7110710-SP	SCREW 11/64-40 L=7	マルヒラネジ 11/64-40 L=7	1
20		226-86000	NEEDLE BAR OIL SEAL FELT. A	ハリホウユホウフェルト A	1
21		226-85804	NEEDLE BAR OIL SEAL PLATE	ハリホウユホウハシ	1
22		SS-6060510-TP	SCREW 3/32-56 L=4.5	ヒラネジ 3/32-56 L=4.5	1
23		226-86158	OIL SEAL FELT ASM., B	ハリホウユホウフェルトB(クミ)	1
24		226-81407	NEEDLE BAR STOPPER	ハリホウストッパ	2
25		226-81506	SPRING	ハリホウストッパコイル	2
26		226-81308	STOPPER SPRING COVER	ハリホウストッパコイルカバ	1
27		SS-4080610-SP	SCREW 1/8-44 L=6.4	ナハネジ 1/8-44 L=6.4	1
28	#01	B1438-512-B00	WASHER 17.1X28X1.5	ヨートメシクメタルチカネ T=1.5	1
29		226-07303	BUSHING	ハリホウヨウトウジクマメタル	1
30		226-07402	BUSHING	ハリホウヨウトウジククシロメタル	1
31		226-07006	REAR ARM	ハリホウヨウトウコウワウテ	1
32		SS-6152440-SP	SCREW 15/64-28 L=23.5	ヒラネジ 15/64-28 L=23.5	1
33		SD-0870601-SP	HINGE SCREW D= 8.73 H= 6.0	タネネジ D=8.73 H=6	2
34		NS-6150430-SP	NUT 15/64-28	ロウカクナツト 15/64-28	2
35		226-07105	DRIVING ROD	ハリホウヨウトウロッド	1
36		226-07204	DRIVING ARM	ハリホウヨウトウオクリウテ	1
37		SS-6121610-TP	SCREW 3/16-28 L=15.5	ヒラネジ 3/16-28 L=15.5	1
38		226-85168	NEEDLE BAR UNIT, LEFT	ハリホウ(ヒタリ)クミ	1
39		226-85150	NEEDLE BAR ASM., LEFT	ハリホウ(ヒタリ)ケツコウ	(1)
40		226-85101	NEEDLE BAR, LEFT	ハリホウ(ヒタリ)	(1)
41		226-85200	SEESAW PLATE	シーソーイタ	(1)
42		226-85408	NEEDLE BAR PIN	ハリホウピン	(1)
43		B1416-528-000	COLLAR	ハネケ	(1)
44		B1425-526-000	SCREW 1/8-44 L=6	ハリトメメネジ	(1)
45		B1402-528-FAL-A	NEEDLE CLAMP ASM. 1/4	ハリトメヒタリ 1/4 クミ	(1)
46		B1425-526-000	SCREW 1/8-44 L=6	ハリトメメネジ	(1)
47		226-85366	NEEDLE BAR UNIT, RIGHT	ハリホウ(ミキ)クミ	1
48		226-85358	NEEDLE BAR ASM., RIGHT	ハリホウ(ミキ)ケツコウ	(1)
49		226-85309	NEEDLE BAR, RIGHT	ハリホウ(ミキ)	(1)
50		226-85200	SEESAW PLATE	シーソーイタ	(1)
51		226-85408	NEEDLE BAR PIN	ハリホウピン	(1)
52		B1416-528-000	COLLAR	ハネケ	(1)
53		B1425-526-000	SCREW 1/8-44 L=6	ハリトメメネジ	(1)
54		B1402-528-FAR-A	NEEDLE CLAMP ASM. 1/4	ハリトメミキ 1/4 クミ	(1)
55		B1425-526-000	SCREW 1/8-44 L=6	ハリトメメネジ	(1)
56		WDP-500B1400	NEEDLE DPX5 #14	ハリ DPX5 #14	2
57		226-83056	NEEDLE BAR CONNECTION ASM.	ハリホウウタキ(クミ)	1
58		SS-7060310-SP	SCREW 3/32-56 L=3	マルヒラネジ 3/32-56 L=3	(1)
59		226-83205	RELEASE PIN COVER	リリースピンフタ	(1)
60		226-83304	SPRING	リリースピンコイル	(1)
61		226-83106	RELEASE PIN	リリースピン	(1)
62		226-83809	SPRING	ハリホウクラッチコイル	(2)
63		226-83007	NEEDLE BAR CONNECTION	ハリホウウタキ	(1)
64		226-83403	NEEDLE BAR CONNECTION PIN	ハリホウウタキピン	(2)
65		226-84104	SPRING	クラッチストップコイル	(2)
66		SS-6080340-SP	SCREW 1/8-44 L=3.0	ヒラネジ 1/8-44 L=2.9	(2)
67		226-84203	SPRING BRACKET	クラッチストップコイルササエ	(1)
68		226-83908	CLUTCH STOPPER, LEFT	ハリホウクラッチストップ(ヒタリ)	(1)
69		226-84005	CLUTCH STOPPER, RIGHT	ハリホウクラッチストップ(ミキ)	(1)
70		226-83502	NEEDLE BAR CLUTCH	ハリホウクラッチ	(2)
71		226-83700	CLUTCH PIN	ハリホウクラッチピン	(2)
72		226-83601	CLUTCH LEVER	クラッチレバー	(2)
73		CQ-2520000-00	OIL WICK	エジン	(0.1)
74		226-84609	NEEDLE BAR CRANK ROD	ハリホウクランクロッド(カタハリツキ)	1
75	#01	226-84906	NEEDLE BAR GUIDE BLOCK	ハリホウアンナイカクマ(カタハリツキ)C	1
76		226-85705	OIL GUARD RUBBER	ホウコム(カタハリツキ)	1

From the library of: Diamond Needle Corp

4. TENSION POST COMPONENTS
糸調子関係

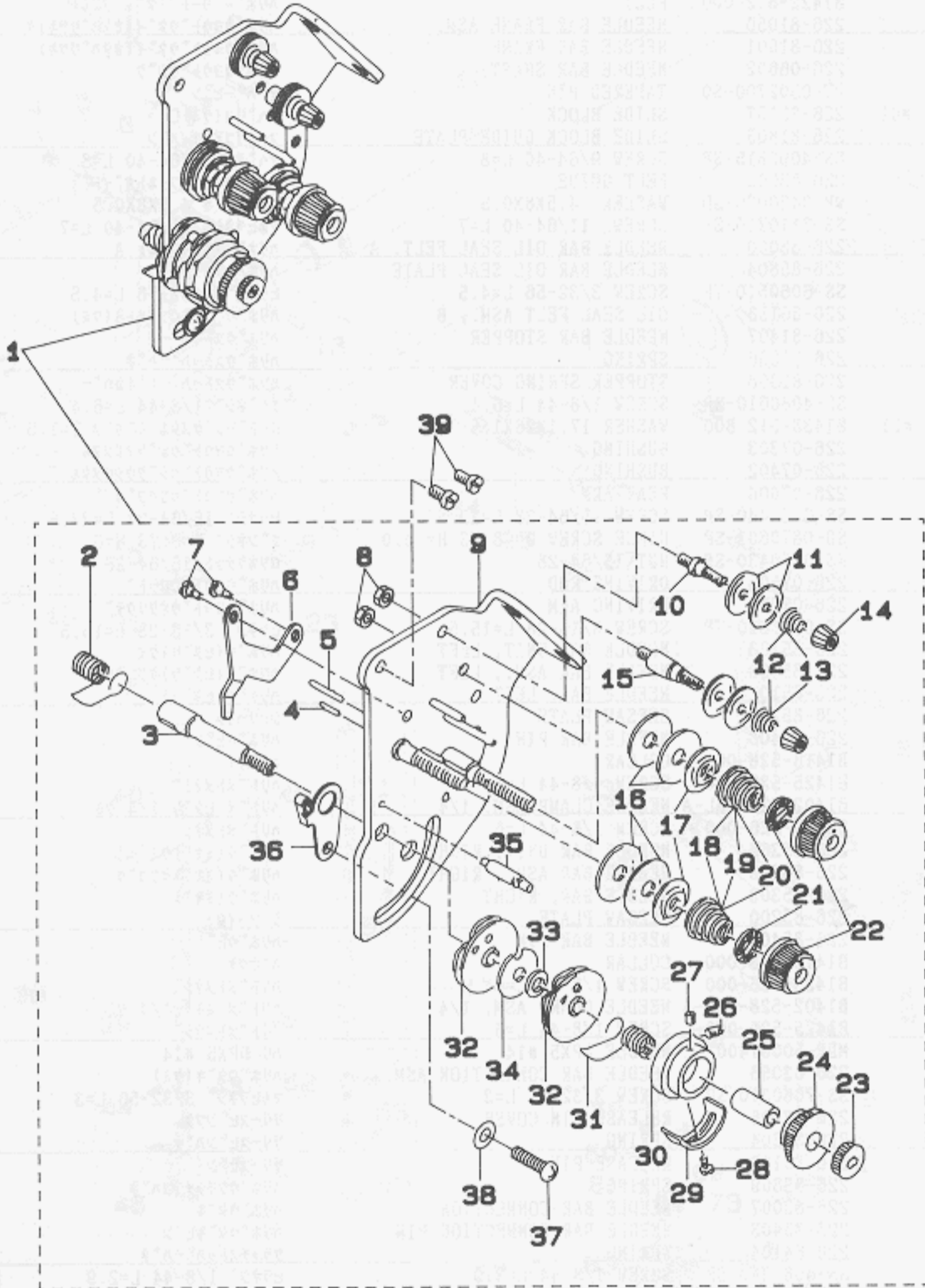

From the library of: Diamond Needle Corp

REF.NO	NOTE	PART NO.	DESCRIPTION	ヒンメイ	Qty
1		226-18060	THREAD TENSION ASM., S	イトヨウシ(クミ)S	1
2		B3128-051-000	THREAD TAKE-UP SPRING, A	イトリハネ	(1)
3		106-97605	THREAD TAKE-UP SPRING STUD	イトリハネ シク	(1)
4		226-18201	TENSION RELEASE PIN, A	イトルメピン(A)	(1)
5		226-18300	TENSION RELEASE PIN, B	イトルメピン(B)	(1)
6		226-18102	TENSION RELEASE LEVER	イトルメイタ	(1)
7		SD-0470281-SP	HINGE SCREW D=4.7 H=2.8	タネネジ D=4.7 H=2.8	(2)
8		NS-6110310-SP	NUT 11/64-40	ロツカクナツト 11/64-40	(2)
9		226-18052	TENSION BASE PLATE ASM.	イトヨウシイタ(ケツコウ)	(1)
10		101-24204	THREAD TENSION POST, A	タイルイトヨウシホ-A	(1)
11		B3214-047-000	BOBBIN WINDER TENSION DISC	イトヨウシ サラ	(4)
12	#01	110-45101	THREAD TENSION SPRING	タイルイチ イトヨウシハネ	(2)
13	#03	110-93606	THREAD TENSION SPRING	タイルイチ イトヨウシハネ	(2)
14		110-72402	THREAD TENSION NUT	タイル1 イトヨウシ ナツト	(2)
15		101-24303	THREAD TENSION POST, B	タイルイトヨウシホ-B	(1)
16		B3126-012-000	THREAD TENSION DISK	イトヨウシサラ	(4)
17		B3132-552-000	THREAD TENSION DISK PRESSER	イトヨウシ サラオサエ	(2)
18	#02	B3129-012-A00	TENSION SPRING	イトヨウシハネ A	(2)
19	#04	D3129-555-D00	THREAD TENSION SPRING	イトヨウシハネ	(2)
20	#03	B3114-232-000	THREAD TENSION SPRING	イトヨウシハネ	(2)
21		B3112-704-000	TENSION SPRING BUSHING	ハネ フツシユ	(2)
22	#01	119-56802	THREAD TENSION KNOB, BLUE	イトヨウシツマミ (アオ)	(2)
23	#01	B3125-012-000	THREAD TENSION NUT	イトヨウシ ナツト	(1)
24		B3125-527-000	TAKE-UP SPRING GUIDE	イトリ ハネカケ	(1)
25		B3141-527-000	PRESSER COLLAR	イトリハネ アンナイオサエ	(1)
26		SS-8080610-SP	SCREW 1/8-44 L=5.5	トメネジ 1/8-44 L=5.5	(1)
27		SS-8080410-TP	SCREW 1/8-44 L=3.5	トメネジ 1/8-44 L=3.5	(1)
28		SS-7090520-SP	SCREW 9/64-40 L= 4.5	マルヒラネジ 9/64-40 L=4.5	(1)
29		B3138-527-000	ADJUSTING PLATE B	イトリハネ チョウセツイタ B	(1)
30		B3140-527-000	THREAD TENSION POST	イトリハネ カケトタイル	(1)
31		B3128-527-000	THREAD TAKE-UP SPRING B	イトリハネ B	(1)
32		B3137-527-0A0	TAKE-UP SPRING GUIDE ASM.	イトリハネ アンナイ クミ	(2)
33		B3139-527-000	COLLAR	イトリハネ シクカラ	(1)
34		B3142-527-000	TAKE-UP SPRING GUIDE PLATE	イトリハネ アンナイイタ	(1)
35		B3143-527-000	TAKE-UP SPRING GUIDE STUD	イトリハネ カケトタイルシク	(1)
36		106-97506	THREAD TENSION BRACKET, A	イトリハネ チョウセツイタ(A)	(1)
37		SS-4110615-SP	SCREW 11/64-40 L=6	ナハコネジ	(1)
38		WP-0501016-SD	WASHER 5X10.5X1	ヒラサカネ 5X10.5X1	(1)
39		SS-4120615-SP	SCREW 3/16-28 L=6	ナハネジ 3/16-28 L=6	2

Note (注記) #01...FOR TYPE A, S
 #02...FOR TYPE S
 #03...FOR TYPE G
 #04...FOR TYPE A,

A, S 仕様用
 S 仕様用
 G 仕様用
 A 仕様用

From the library of: Diamond Needle Co.

5. HOOK & HOOK DRIVING SHAFT COMPONENTS
 釜・下軸関係

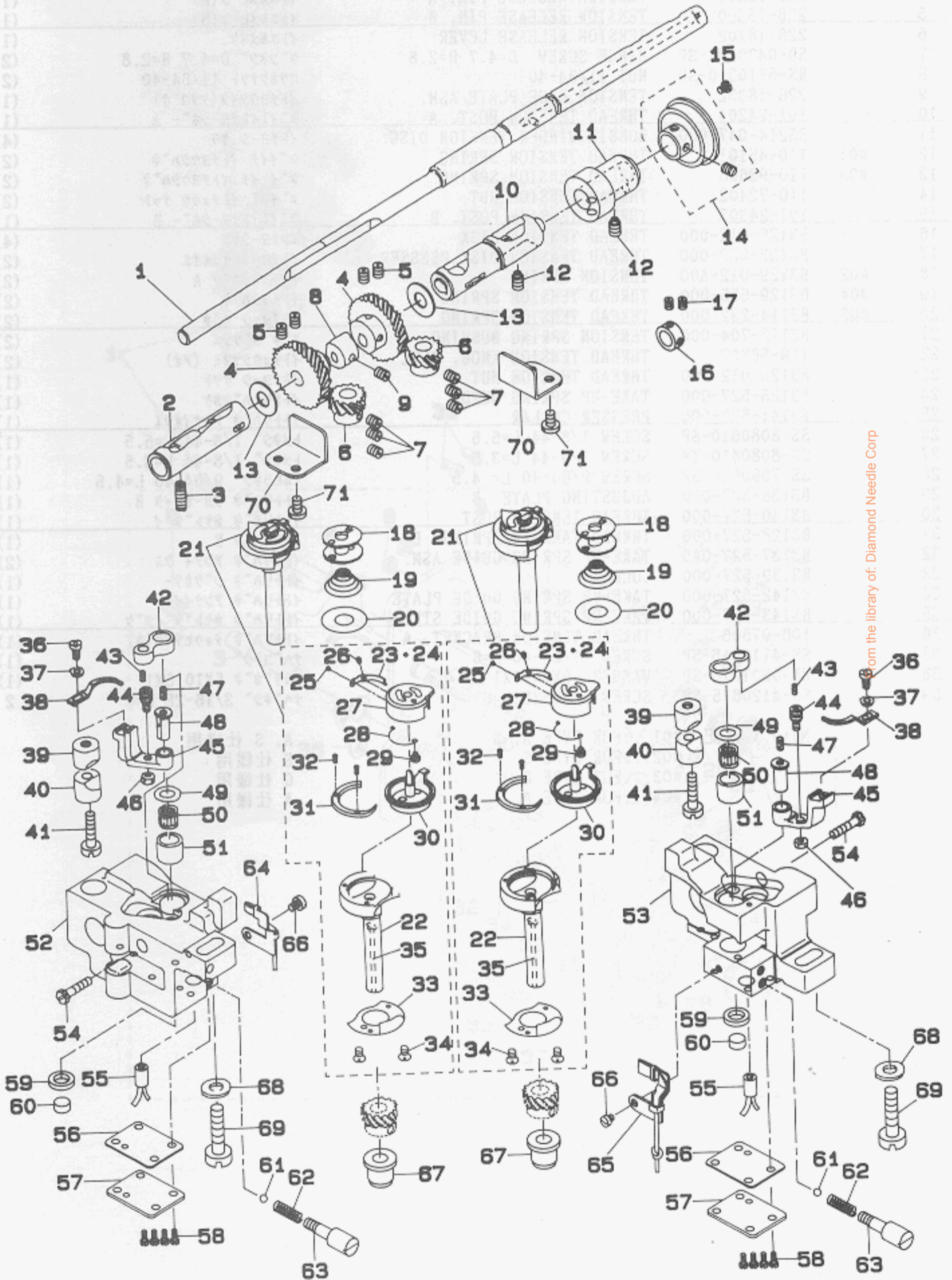

From the library of: Diamond Needle Corp

REF. NO	NOTE	PART NO.	DESCRIPTION	ヒ ン メ イ	Qty
1		101-08512	HOOK DRIVING SHAFT	シタジク	1
2	#01	B1802-512-0A0-A	BUSHING ASM., FRONT	シタジク マイメタル クミ	1
3		SS-8151150-SP	SCREW 15/64-28 L=10.5	トメネジ 15/64-28 L=10.5	1
4		B1816-512-000	HOOK DRIVING SHAFT, LARGE	シタジク ネジハクマ	2
5		SS-8660810-TP	SCREW 1/4-40 L=8	トメネジ 1/4-40 L=8	4
6	#01	101-12001	HOOK SHAFT GEAR, A	カマジク ネジハクマ A	2
7		SS-8660530-TP	SCREW 1/4-40 L= 4.5	トメネジ 1/4-40 L=4.5	6
8		226-09804	FEED DRIVING CAM	シヨウケ オクリカム	1
9		SS-8660530-TP	SCREW 1/4-40 L= 4.5	トメネジ 1/4-40 L=4.5	1
10	#01	B1803-515-0A0	BUSHING ASM., INTERMEDIATE	シタジク ナカメタル クミ	1
11		101-08611	PLUNGER BUSHING	シタジク プランジヤメタル	1
12		SS-8151150-SP	SCREW 15/64-28 L=10.5	トメネジ 15/64-28 L=10.5	2
13		226-13707	THRUST WASHER	シタジクハクマ スラストハクマ	2
14		106-11457	THRUST COLLAR ASM.	シタジク スラスト ウケ(クミ)	1
15		SS-7120760-SP	SCREW 3/16-28 L= 7.0	マルヒラネジ 3/16-28 L=7	2
16		CS-1471012-SH	THRUST COLLAR D=14.72 W=10	スラストウケ D=14.72 W=10	1
17		SS-8660530-TP	SCREW 1/4-40 L= 4.5	トメネジ 1/4-40 L=4.5	2
18		102-10805	HARD ALUMITE BOBBIN	コウシツアルマイト ボビン	2
19		101-11508	SPRING	クーテンボビンシハネ	2
20		226-53802	SHEET	クウデンボビンシート	2
21		226-93857	HOOK ASM.	イトキリカタハリカマ(クミ)	2
22		226-88006	HOOK	ソトガマ	(2)
23	#01	226-88402	TENSION ADJUSTING SPRING	シタイトショウシハネ(0.3)	(2)
24	#01	226-88501	TENSION ADJUSTING SPRING	シタイトショウシハネ(0.25)	(2)
25		101-10500	TENSION SPRING INSTALLING SCRE	シタイトショウシハネ トメネジ	(2)
26		101-10609	TENSION ADJUSTING SCREW	シタイトショウシハネ トメネジ	(2)
27		226-88105	BOBBIN CASE	ボビンケース(カタハリヨウ)	(2)
28		226-88204	SPRING	シタイトキョウシハネ	(2)
29		SS-6560150-SH	SCREW 3/32-80 L=1.3	ヒラネジ 3/32-80 L=13.2	(2)
30		226-53000	SEWING HOOK	キャップナカガマ(イトキリツキ)	(2)
31		226-53307	HOOK GIB	ナカガマオキ(イトキリツキ)	(2)
32		101-12803	SCREW	オキエトメネジ	(4)
33		226-12303	NEEDLE POSITIONER	ハリウケ	(2)
34	#02	101-12803	SCREW	ハリウケトメネジ	(4)
35		226-12501	LILYYARN	リリアン(カマ)	(2)
36		SS-6090810-SP	SCREW 9/64-40 L= 7.5	ヒラネジ 9/64-40 L=7.5	2
37		WP-0371016-SD	WASHER 3.7X8X1	ヒラサカネ 3.7X8X1	2
38		226-13509	BOBBIN CASE OPENING LEVER	ナカガマアンナイ(コガマ)	2
39		101-09908	SADDLE INSTALLING BLOCK, UPPER	カマジクイットメ ウエ	2
40		101-12407	SADDLE INSTALLING BLOCK, LOWER	カマジクイットメ シタ	2
41		SS-6153040-SP	SCREW 15/64-28 L=30	ヒラネジ 15/64-28 L=30	2
42		B1820-051-000	BOBBIN CASE OPENING LEVER LINK	ナカガマ アンナイ リンク	2
43		CQ-2020000-00	OIL WICK	ユジン	0.1
44		B1821-051-000	CRANK SCREW STUD	ナカガマ アンナイ クランクピオン	2
45		B1822-051-000	OPENING LEVER CRANK	ナカガマ アンナイウテ	2
46		NS-6110420-SP	NUT 11/64-40	ロツカクナツ 11/64-40	2
47		CQ-2020000-00	OIL WICK	ユジン	0.1
48		B1823-051-000	OPENING LEVER CRANK PIN	ナカガマ アンナイウテ シク	2
49		101-11201	THRUST WASHER, F	カマジクウイメタル スラストイタ 1.4	2
50	#01	SB-3095301-OC	NEEDLE BEARING 9.525X9.52	ニトメハアリング 9.525X9.52	2
51		226-13251	BUSHING	カマジクウイメタル(ケツコウ)コガマ	2
52		226-53604	HOOK SHAFT SADDLE, LEFT	イトイリカマシクイ(ヒタリ)コガマ	1
53		226-53505	HOOK SHAFT SADDLE, RIGHT	イトキリカマシクイ(ミキ)コガマ	1
54		SS-9111820-SP	SCREW 11/64-40 L=18	ロツカクホルト 11/64-40 L=18	2
55		226-15454	RUBBER BUSHING ASM.	ゴムフツシユ(ケツコウ)	2
56		226-15108	GASKET	カマジクハッキン	2
57		226-15009	HOOK SHAFT SADDLE COVER	カマジクイットメ	2
58		SS-4110815-SP	SCREW 11/64-40 L=8	ナハネジ 11/64-40 L=8	8
59		226-15306	FELT HOLDER	フェルトホルダー	2
60		226-15207	FELT	カマジクシタフェルト	2
61		226-15702	OIL ADJUSTING BALL	カマシヨウショウセツボール	2
62		D3171-415-BOH	PRESSER SPRING	イトユルメ モトシ ハネ	2
63		226-15801	OIL ADJUSTING SCREW	カマシヨウショウセツネジ	2
64		226-15959	OIL WICK HOLDER ASM. LEFT	ヒタリハクマ ユジンササ(クミ)	1
65		101-26654	OIL WICK HOLDER ASM. RIGHT	ミキハクマ ユジンササ(クミ)	1
66		SS-6110480-SP	SCREW 11/64-40 L=4.3	ヒラネジ 11/64-40 L=4.3	2
67		226-13400	HOOK DRIVING SHAFT BUSHING	カマジクシタメタル	2
68		WP-0850002-SP	WASHER 8.5X18X1.6	ヒラサカネ 8.5X18X1.6	2
69		SM-7082550-SP	SCREW M8 L=25	マルヒラネジ M8 L=25	2
70		226-13608	GEAR GUIDE	シタジクネジハクマカイト	2
71		SS-7110710-SP	SCREW 11/64-40 L=7	マルヒラネジ 11/64-40 L=7	4

From the library of: Diamond Needle Corp

6. FEED MECHANISM COMPONENTS
送り関係

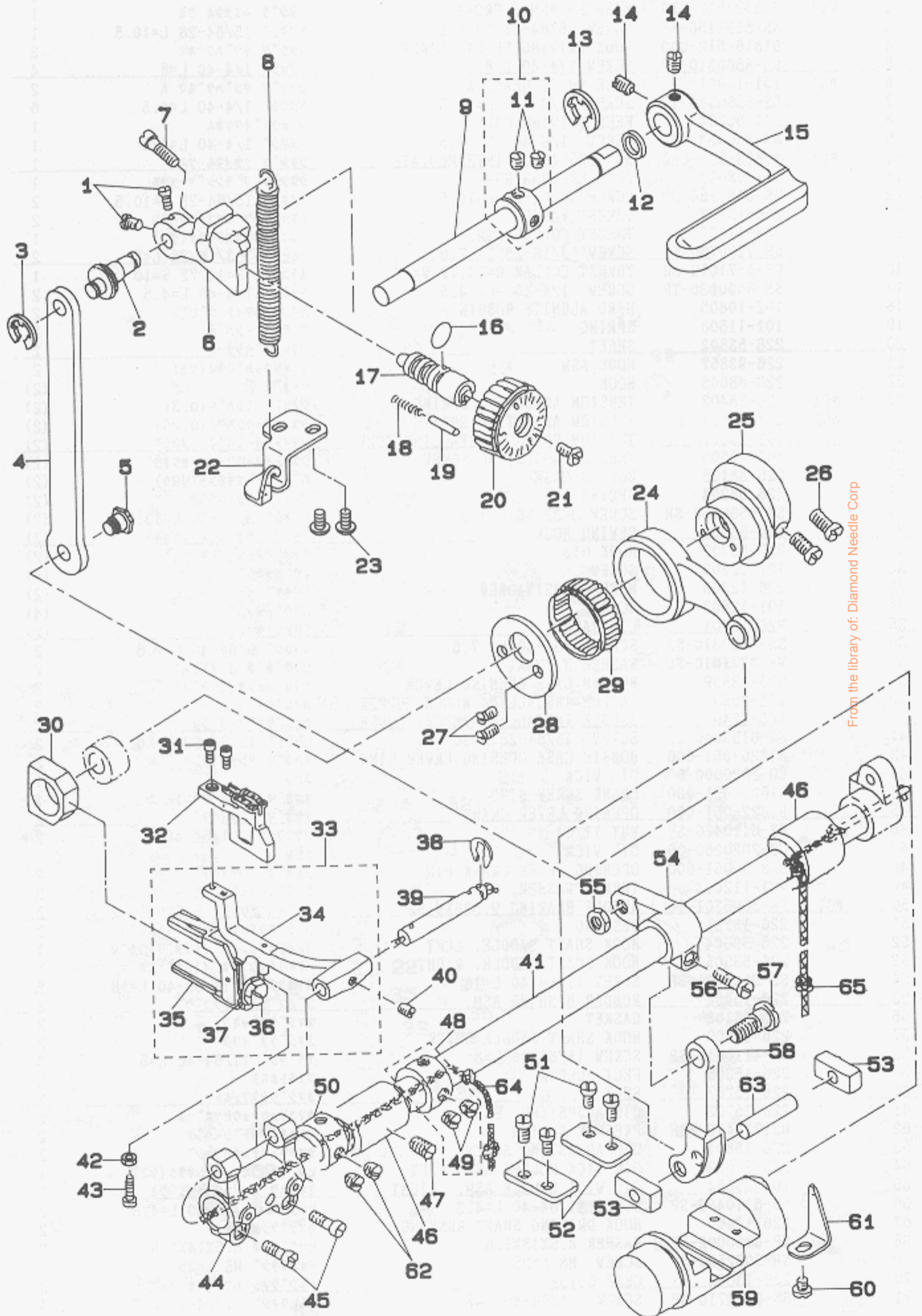

From the library of: Diamond Needle Corp

REF.NO	NOTE	PART NO.	DESCRIPTION	ヒンメイ	Qty
1		SS-6090670-TP	SCREW 9/64-40 L=6	ヒラネジ 9/64-40 L=6	2
2		226-10109	ROD PIN	オクリチョウセツタ ^イ ヒ ^ン	1
3		RE-0500000-KO	E-RING	Eカ ^タ メワ 5	1
4		226-10208	FEED REGULATOR CONNECTING ROD	オクリチョウセツロツト ^イ	1
5		SD-0800422-CP	HINGE SCREW D= 8 H= 4.2	タ ^ン ネジ D=8 H=4.2	1
6		226-10000	FEED REGULATOR	オクリチョウセツタ ^イ	1
7		SS-7121410-SP	SCREW 3/16-28 L=14	マルヒラネジ 3/16-28 L=14	1
8		226-10307	FEED REGULATOR SPRING	オクリチョウセツタ ^イ ハ ^ネ	1
9	#01	226-52101	REVERSE FEED SHAFT	キ ^{ャク} オクリレハ ^シ ク(イトキリツキ)	1
10		CS-102121A-SH	THRUST COLLAR ASM. D=10.2 W=12	スラストウケ D=10.2 W=12 クミ	1
11		SS-8660610-TP	SCREW 1/4-40 L=6	トメネジ 1/4-40 L=6	(2)
12		101-08009	OIL SEAL	キ ^{ャク} オクリレハ ^シ ク オイルシール	1
13		RE-0900000-KO	SNAP RING 9.0	Eカ ^タ メワ 9	1
14		SS-8120740-SP	SCREW 3/16-28 L=7	トメネジ 3/16-28 L=7	2
15		226-10505	REVERSE FEED CONTROL LEVER	キ ^{ャク} オクリレハ ^シ	1
16		RO-0922702-00	RUBBER RING	オリンク ^イ	1
17		110-09909	FEED REGULATOR SCREW	オクリチョウセツネジ ^イ	1
18		B1148-555-000	SPRING	オクリ チョ ^ウ セツ ヒ ^ン ハ ^ネ	1
19		110-52701	PIN	オクリ チョウセツ ヒ ^ン	1
20		110-71909	FEED DIAL	オクリタ ^イ ヤル	1
21		SS-6121860-SP	SCREW	ヒラネジ	1
22		226-10406	SPRING BRACKET	オクリチョウセツタ ^イ ハ ^ネ ウケ	1
23		SS-4110815-SP	SCREW 11/64-40 L=8	ナ ^ハ ネジ 11/64-40 L=8	2
24		226-09200	FEED ROCK SHAFT CONNECTING ROD	スイハイオクリロツト ^イ	1
25		226-52002	FEED DRIVE ECCENTRIC CAM	スイハイオクリカム	1
26		SS-6661110-SP	SCREW 1/4-40 L=11	ヒラネジ 1/4-40 L=11	2
27		SS-7110710-SP	SCREW 11/64-40 L=7	マルヒラネジ 11/64-40 L=7	2
28		226-09101	CAM COVER	スイハイオクリカムカマ	1
29		B1636-581-B00	NEEDLE BEARING B	ニ ^ー トル ハ ^ア リンク ^イ B	1
30		B1610-512-000	FEED DRIVING SLIDE BLOCK	シ ^ョ ウ ^キ オクリ カクゴ ^マ	1
31		SS-6580752-TP	SCREW 1/8-40 L=7	ロツカクナホ ^ネ 1/8-40 L=6.3	2
32	#02	102-38202	FEED DOG 1/4	イトキリオクリハ ^シ 2マル 1/4	1
33		226-09754	FEED BAR ASM.	オクリタ ^イ (クミ)	1
34		226-09705	FEED BAR	オクリタ ^イ	(1)
35		101-07902	FEED BAR FORK	オクリタ ^イ フタマタ	(1)
36		SS-9151440-CP	SCREW 15/64-28 L=14	ロツカクホ ^ネ 15/64-28 L=14	(1)
37		WP-0621016-SD	WASHER 6.2X13X1	ヒラサ ^カ ネ 6.2X13X1	(1)
38		RE-0500711-KP	SNAP RING 5	Uカ ^タ メワ 5	1
39		B1604-012-000-A	FEED BAR SHAFT	オクリタ ^イ シ ^ク	1
40		SS-8620610-TP	SCREW 3/16-32 L=6	トメネジ 3/16-32 L=6	1
41		226-09408	FEED ROCK SHAFT	スイハイオクリシ ^ク	1
42		NS-6080210-SP	NUT 1/8-44	ロツカクナツト 1/8-44	1
43		SS-6081810-SP	SCREW 1/8-44 L=18.0	ヒラネジ 1/8-44 L=18	1
44		B1603-512-000	FEED ROCKER	オクリタ ^イ ウテ ^イ	1
45		SS-7111310-TP	SCREW 11/64-40 L=12.8	マルヒラネジ 11/64-40 L=12.8	2
46		101-06102	BUSHING	スイハイオクリシ ^ク マイメタル	2
47		SS-8151150-SP	SCREW 15/64-28 L=10.5	トメネジ 15/64-28 L=10.5	1
48		CS-147121B-SH	THRUST COLLAR ASM. D=14.72 W=1	スラストウケ D=14.72 W=12 クミ	1
49		SS-8660530-TP	SCREW 1/4-40 L= 4.5	トメネジ 1/4-40 L=4.5	(2)
50		CS-1471012-SH	THRUST COLLAR D=14.72 W=10	スラストウケ D=14.72 W=10	1
51		SS-7110910-SP	SCREW	マルヒラネジ 11/64-40 L=8.5	4
52		103-15505	PLATE	オクリ チョウセツタイフタ	2
53		226-09606	FEED DRIVING ROCKER BLOCK, S	オクリチョウセツタイカクゴ ^マ S	2
54		226-09309	FEED ROCKER SHAFT CRANK	スイハイオクリウテ ^イ	1
55		NS-6680320-SP	NUT 9/32-28	ロツカクナツト 9/32-28	1
56		SS-6121610-TP	SCREW 3/16-28 L=15.5	ヒラネジ 3/16-28 L=15.5	1
57		SD-0900701-TP	HINGE SCREW D= 9 H= 7	タ ^ン ネジ D=9 H=7	1
58		103-15208	FEED ROCK CONNECTING ROD	スイハイオクリ レンラクカ ^ン	1
59		103-15455	FEED DRIVING ROCKER ASM.	オクリチョウセツタイ クミ	1
60		SS-7110510-SP	SCREW 11/64-40 L=5	マルヒラネジ 11/64-40 L= 5	1
61		B1633-470-000	STOPPER PLATE	オクリチヨ ^ウ セツタイ ウケイタ	1
62		SS-8660530-TP	SCREW 1/4-40 L= 4.5	トメネジ 1/4-40 L=4.5	2
63		B1653-470-000	PIN	カクゴ ^マ ヒ ^ン	1
64		CQ-2520000-00	OIL WICK	ウシ ^ン	0.5
65		CQ-3030000-00	OIL WICK	ウシ ^ン	0.3

Note (注記) #01...FOR -WB, -OB -WB, -OB 用
#02...EXCHANGING GAUGE PART 交換ゲージ部品

From the library of: Diamond Needle Corp.

7. PRESSER BAR & TENSION RELEASE COMPONENTS
 押さえ棒・糸ゆるめ関係

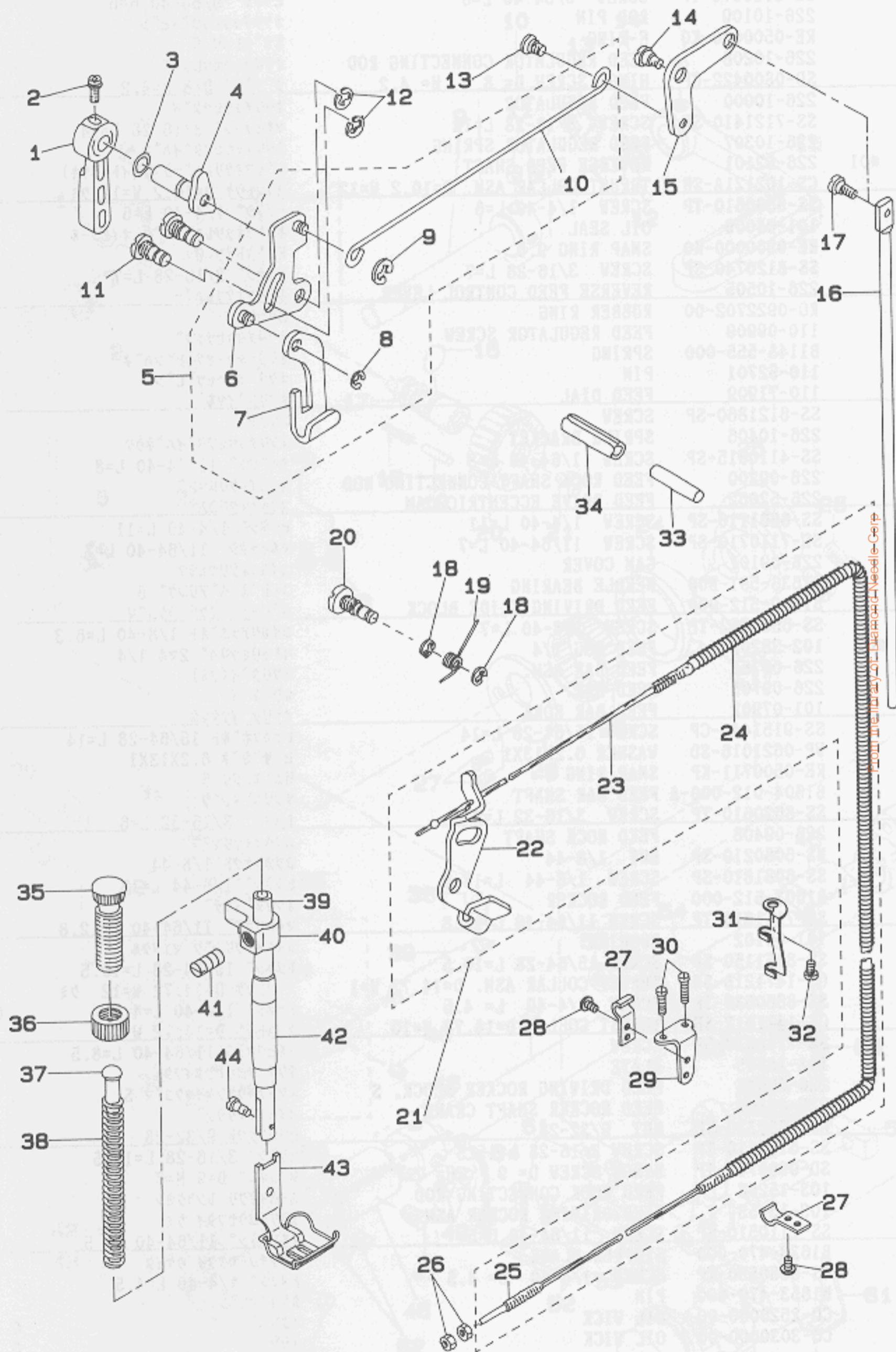

REF.NO	NOTE	PART NO.	DESCRIPTION	ヒンメイ	Qty
1		110-71800	HAND LIFTER	オサエアケ レハ-	1
2		B1521-555-000	SCREW	オサエアケレハ- トメネジ	1
3		RO-0371801-00	RUBBER RING	Oリング	1
4		110-06756	HAND LIFTER CAM ASM.	オサエアケカム クミ	1
5		226-08152	LIFTING LEVER ROD ASM.	ヒサアケヨコホウ(クミ)	1
6		110-06350	HAND LIFTER LINK	ヒキアケリンク クミ	(1)
7		110-06202	LIFTING LEVER	ヒキアケイタ	(1)
8		110-07309	LIFTING LEVER RING	ヒキアケ リンク タリンク	(1)
9		RE-0500000-K0	E-RING	Eカトメワ 5	(1)
10		226-08103	LIFTING LEVER CONNECTING ROD	ヒサアケヨコホウ	(1)
11		110-06509	LINK SHAFT	ヒキアケリンクシク	2
12		RE-0500000-K0	E-RING	Eカトメワ 5	2
13		110-07101	HINGE SCREW	ヒサアケ ヨコホウネジ	1
14		SD-0720332-SP	HINGE SCREW D= 7.24 H= 3.3	タネネジ D=7.24 H=3.3	1
15		110-07002	LIFTING LEVER LINK	ヒサアケリンク	1
16		101-25201	CONNECTING ROD, VERTICAL	ヒサアケレンケツホ-	1
17		SD-0600322-SD	HINGE SCREW D=6 H=3.2	タネネジ D=6 H=3.2	1
18		RE-0500000-K0	E-RING	Eカトメワ 5	3
19		110-18207	TENSION RELEASE RETURN SPRING	イトユルメイタ モトシハネ	1
20		110-18108	TENSION RELEASE SHAFT	イトユルメイタシク	1
21		226-54958	TENSION RELEASE PLATE ASM.	サラムメイタ(クミ)	1
22		226-17104	TENSION RELEASE PLATE	サラムメイタ	(1)
23		113-94509	WIRE CABLE	ワイヤ ケーブル (ケツコウ)	(1)
24		226-54909	WIRE TUBE	ワイヤチューブ	(1)
25		D3159-555-B00	SET SCREW	ワイヤ セットネジ	(1)
26		NS-6620310-SP	NUT 3/16-32	ロツカクナツト 3/16-32	2
27		D3164-555-B00	OUTER PRESSER PLATE	アウターオサエ	2
28		SS-4110715-SP	SCREW 11/64-40 L=7	ナネネジ 11/64-40 L=7	2
29		D3163-555-B00-A	FLEXIBLE TUBE SUPPORT PLATE	フレキシブル トリツケタ	1
30		SS-4111215-SP	SCREW 11/64-40 L=12	ナネネジ 11/64-40 L=12	2
31		113-06206	WIRE CABLE HOLDER	ワイヤ ケーブル アテ	1
32		SS-4110715-SP	SCREW 11/64-40 L=7	ナネネジ 11/64-40 L=7	1
33		226-17005	PUSH BAR	サラクカシオシホウ	1
34		PS-0600502-KP	SPRING PIN	スプリングピン	1
35		110-71602	PRESSER SPRING REGULATOR	オサエ チョウセツ ネジ	1
36		110-71701	NUT	オサエ チョウセツ ネジ ナツト	1
37		B1510-227-000	PRESSER GUIDE BAR	オサエ アンナイホ-	1
38		B1505-227-T00-A	PRESSER SPRING T	オサエ チョセツハネ	1
39		B1501-581-000	PRESSER BAR	オサエホ-	1
40		226-08004	NEEDLE BAR GUIDE BRACKET	オサエホウタキ	1
41		SS-8660810-TP	SCREW 1/4-40 L=8	トメネジ 1/4-40 L=8	1
42		B1502-541-000	PRESSER BAR BUSHING, LOWER	オサエホ- シタメタル	1
43	#01	101-52957	PRESSER FOOT ASM. 1/4"	オサエ (2.0) 1/4 クミ	1
44		SS-7090910-TP	SCREW 9/64-40 L= 8.5	マルヒラネジ 9/64-40 L=8.5	1

Note (注記)#01...EXCHANGING GAUGE PART
(SEE P.29)

交換ゲージ部品
(29 ページご参照下さい。)

From the library of Diamond Needle Corp

8. THREAD TRIMMER MECHANISM COMPONENTS
糸切り装置関係

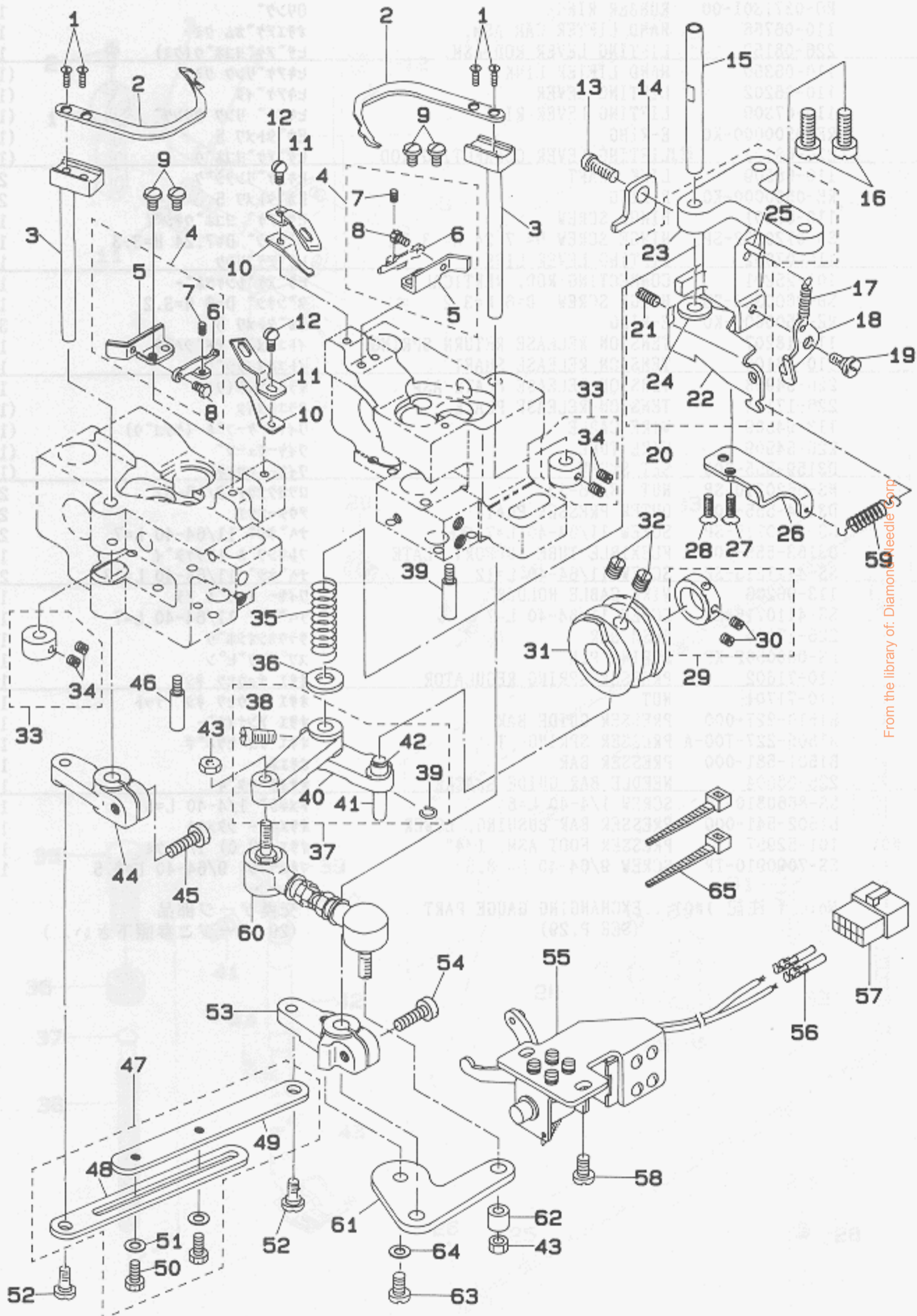

From the library of: Diamond Needle Corp

REF.NO	NOTE	PART NO.	DESCRIPTION	ヒ	ン	メ	イ	Qty
1		SS-2080810-SP	SCREW 1/8-44 L=7.5	マルチラネジ	1/8-44	L=7.5		4
2		102-11605	MOVING KNIFE	トウメス				2
3		101-16051	MOVING KNIFE SHAFT ASM.	トメスジク	クミ			2
4		226-54255	MOVING KNIFE SUPPORT ASM.	トウメスササエ	(クミ)			2
5		226-54206	MOVING KNIFE SUPPORT PLATE	トウメスササエ				(2)
6		102-11407	THREAD PRESSER ADJUSTING PLATE	イトオサエ	チヨウセツカナク			(2)
7		SS-8080610-SP	SCREW 1/8-44 L=5.5	トメネジ	1/8-44	L=5.5		(2)
8		SS-9080410-SP	SCREW 1/8-44 L=4.3	ロツカクホルト	1/8-44	L=4.3		(2)
9		SS-5090610-SP	SCREW 9/64-40 L=6	トラスネジ	9/64-40	L=6		4
10		226-55401	THREAD PRESSER	イトオサエ				2
11		226-55302	COUNTER KNIFE	コテイメス				2
12		SS-7090710-SP	SCREW 9/64-40 L= 6.8	マルヒラネジ	9/64-40	L=6.8		2
13		SS-6121212-TP	SCREW 3/16-28 L=12.0	ロツカクアナホルト	3/16-28	L=12		1
14		226-54800	STOPPER, A	ジユウトウシカイトイタ				1
15		101-16804	SHAFT	カムジユートシジク				1
16		SS-7151610-SP	SCREW 15/64-28 L=16	マルヒラネジ	15/64-28	L=16		2
17		B3418-180-000	SPRING	サトレハハネ				1
18		101-17208	TENSION DISC RELEASE PLATE	チラクカシイタ				1
19		SD-0600271-SP	HINGE SCREW D= 6 H= 2.7	タネネジ	D=6 H=2.7			1
20		226-55153	LINK INSTALLING BASE ASM.	ジユウトウシトリツケタイ	(ケツコウ)			1
21		SS-8111010-TP	SCREW 11/64-40 L=9.5	トメネジ	11/64-40	L=9.5		(1)
22		226-55104	TENSION DISC RELEASE ARM	チラクカシウデ				(1)
23		101-16806	LINK INSTALLING BASE	ジユートシトリツケタイ				(1)
24		101-17109	BUSHING	チラクカシウデメタル				(1)
25		PS-0300201-KP	SPRING PIN 3.0X20	スプリングピン	3.0X20			(1)
26		226-54701	STOPPER PLATE	ジユウトウシストップイタ				1
27		SS-2110920-TP	SCREW 11/64-40 L=8.5	マルチラネジ	11/64-40	L=8.5		1
28		SS-2110930-SP	SCREW 11/64-40 L=8.7	マルチラネジ	11/64-40	L=8.75		1
29		CS-1470710-SH	THRUST COLLAR ASM. D=14.72 W=7	スラストウケ	D=14.72 W=7	クミ		1
30		SS-8110410-TP	SCREW 11/64-40 L= 3.5	トメネジ	11/64-40	L=3.5		(2)
31		226-54107	THREAD TRIMMER CAM	イトキリカム				1
32		SS-8660810-TP	SCREW 1/4-40 L=8	トメネジ	1/4-40	L=8		2
33		CS-070081B-SH	THRUST COLLAR ASM. D=7 W=8	スラストウケ	D=7 W=8	クミ		2
34		SS-8110510-SP	SCREW 11/64-40 L=5	トメネジ	11/64-40	L=5		(4)
35		101-16903	SPRING	ジユートシジク	ハネ			1
36		B1853-512-00C-A	HOOK SHAFT WASHER, C	カムジクサカネ	C			1
37		101-16754	CAM INSTALLING LINK ASM.	カムジユートシ	クミ			1
38		SS-6151220-SP	SCREW 15/64-28 L=11.5	ヒラネジ	15/64-28	L=11.5		(1)
39		D2430-555-B00	SNAP RING	カムローラ	シク	Cリンク		(1)
40		101-16705	CAM INSTALLING LINK	カムジユートシ				(1)
41		D2428-555-B00-A	CAM ROLLER SHAFT	カムローラ	シク			(1)
42		D2427-555-B00-B	CAM ROLLER	カムローラ				(1)
43		NM-6050001-SP	NUT M5	ロツカクナツト	M5X0.8	1シユ		2
44		226-54404	DRIVING ARM, LEFT	ヨウトウウデ	(ヒタリ)			1
45		SS-6121610-TP	SCREW 3/16-28 L=15.5	ヒラネジ	3/16-28	L=15.5		1
46		B1515-051-000	HAND LIFTER PIN	オサエアケ	シク			2
47		226-54552	CONNECTING LINK ASM.	レンケツリンク	(クミ)			1
48		226-54503	CONNECTING LINK, A	レンラクリンク	A			(1)
49		226-54602	CONNECTING LINK, B	レンラクリンク	B			(1)
50		SS-9111010-SP	SCREW 11/64-40 L=9.5	ロツカクホルト	11/64-40	L=9.5		(2)
51		WP-0501016-SD	WASHER 5X10.5X1	ヒラサカネ	5X10.5X1			(2)
52		SD-0650305-TP	HINGE SCREW D= 6.5 H= 3	タネネジ	D=6.5 H=3			2
53		226-54305	DRIVING ARM, RIGHT	ヨウトウウデ	(ミキ)			1
54		SS-6121610-TP	SCREW 3/16-28 L=15.5	ヒラネジ	3/16-28	L=15.5		1
55		101-17851	SOLENOID ASM.	ジユートシシイタ	クミ			1
56	#01	HK-0346400-0B	PIN CONTACT	ピンコンタクト				2
57	#01	HK-0346101-40	HOUSING 14P	ハウジング	14P			1
58		SS-6151040-SP	SCREW 15/64-28 L=10	ヒラネジ	15/64-28	L=10		2
59		B3041-980-000	SPRING	オサエアケ	レハハネ	カイシハネ		1
60		226-55005	JOINT ROD	ジョイントロッド				1
61		226-54008	DRIVING ARM PLATE	ヨウトウウデ	イタ			1
62		B3417-051-000	REAR LIFTING BAR ROLLER	ウシロ	ツリホ	コ		1
63		SS-6120940-SP	SCREW 3/16-28 L=9	ヒラネジ	3/16-28	L=9		1
64		WP-0501016-SD	WASHER 5X10.5X1	ヒラサカネ	5X10.5X1			1
65		EA-9500B01-00	CABLE BAND	ソクセンバンド				2

Note (注記) #01...FOR LH-3162-7

LH-3162-7 用

From the library of: Diafrond Needle Corp

9. AUTOMATIC CHANGE-OVER DEVICE COMPONENTS (1)
 角縫い自動切換装置関係 (1)

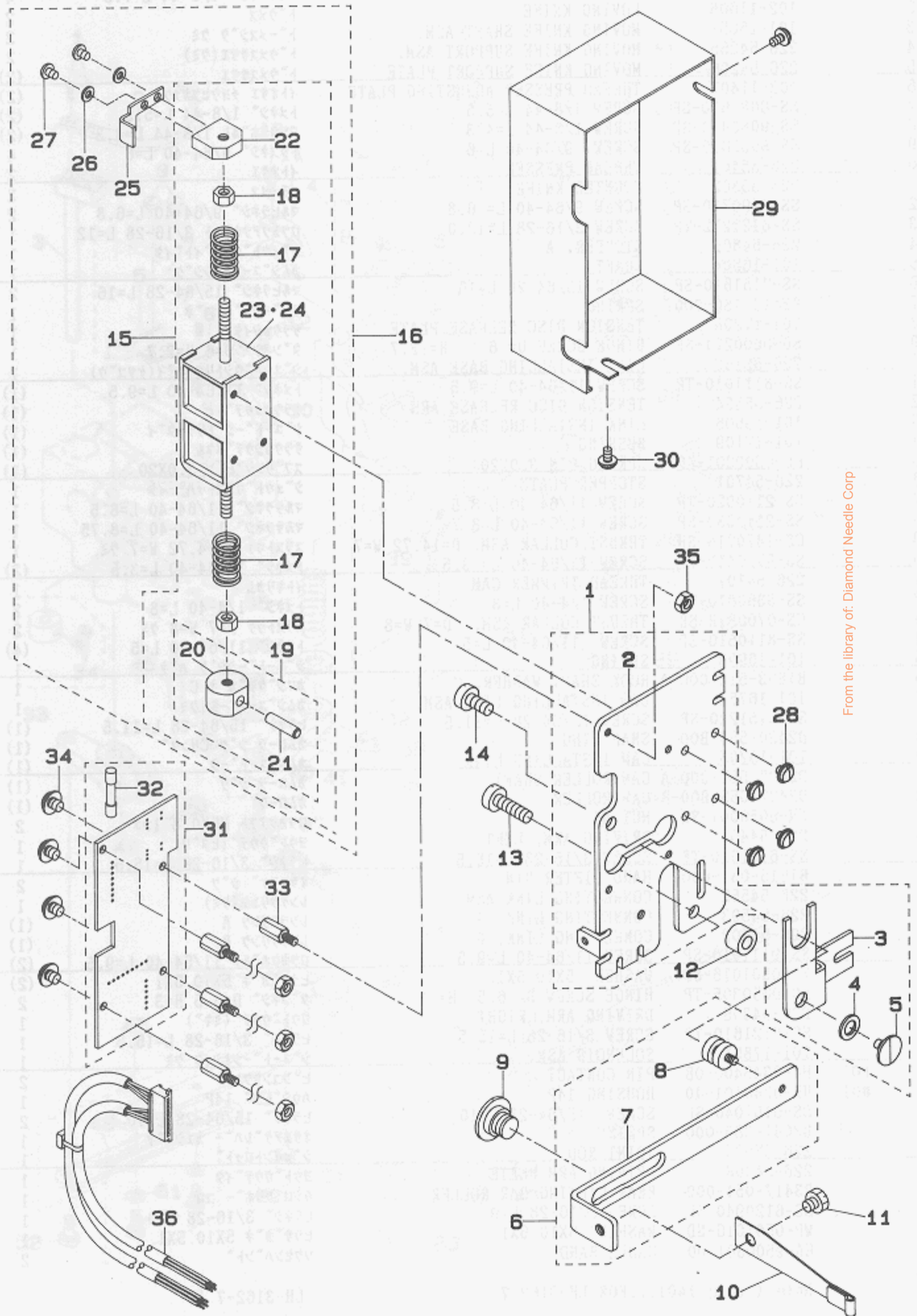

From the library of: Diamond Needle Corp

10. AUTOMATIC CHANGE-OVER DEVICE COMPONENTS (2)
 角縫い自動切換装置関係 (2)

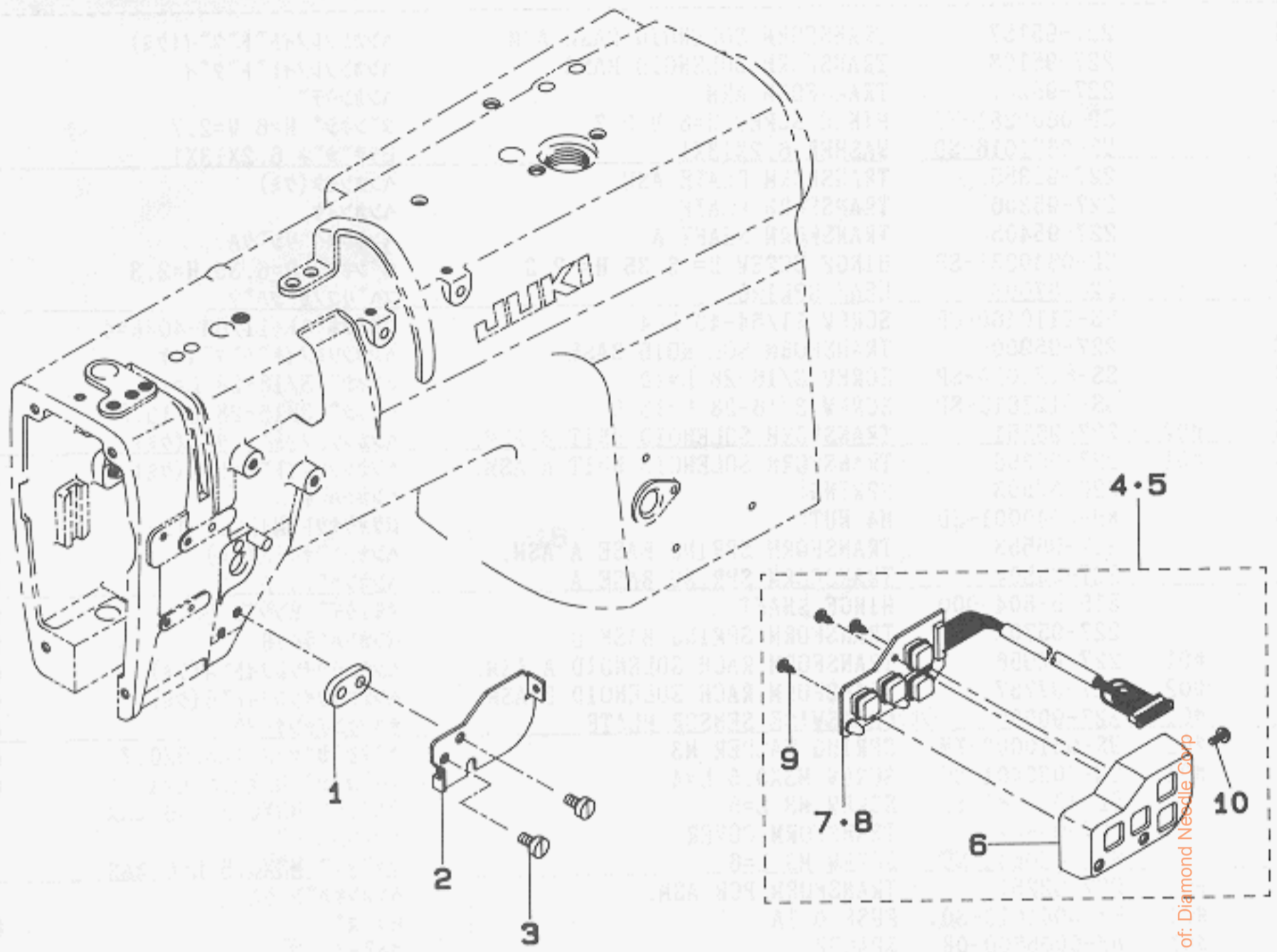

REF.NO	NOTE	PART NO.	DESCRIPTION	ヒソメイ	Qty
1		227-96908	CASE	ケースリツケサ*	1
2		227-96809	CASE FITTING PLATE	ケースリツケイタ	1
3		SS-6120940-SP	SCREW 3/16-28 L=9	ヒラネジ [†] 3/16-28 L=9	2
4	#01	227-90455	OPERATION SWITCH CASE A ASM.	ソウサスイッチケースA (ケミ)	1
5	#02	227-96759	OPERATION SWITCH CASE B ASM.	ソウサスイッチケースB (ケミ)	1
6		227-96700	OPERATION SWITCH CASE	ソウサスイッチケース	(1)
7	#01	227-92758	OPERATION SWITCH PCB A ASM.	ソウサスイッチキハ [†] ンA (ケミ)	(1)
8	#02	227-97559	OPERATION SWITCH PCB B ASM.	ソウサスイッチキハ [†] ンB (ケミ)	(1)
9		ST-4030851-SN	SCREW	タツビ [†] ンネジ [†] D=3-24 L= 8	(3)
10		SL-4030881-SF	SCREW M3 L=8	ナ [†] コネジ [†] セムス M3 L=8	(1)

Note (注記) #01...FOR LH-3162-4
 #02...FOR LH-3162-7

LH-3162-4 用
 LH-3162-7 用

From the library of: Diamond Needle Corp

11. AUTOMATIC REVERSE FEED MECHANISM COMPONENTS

自動逆送り関係

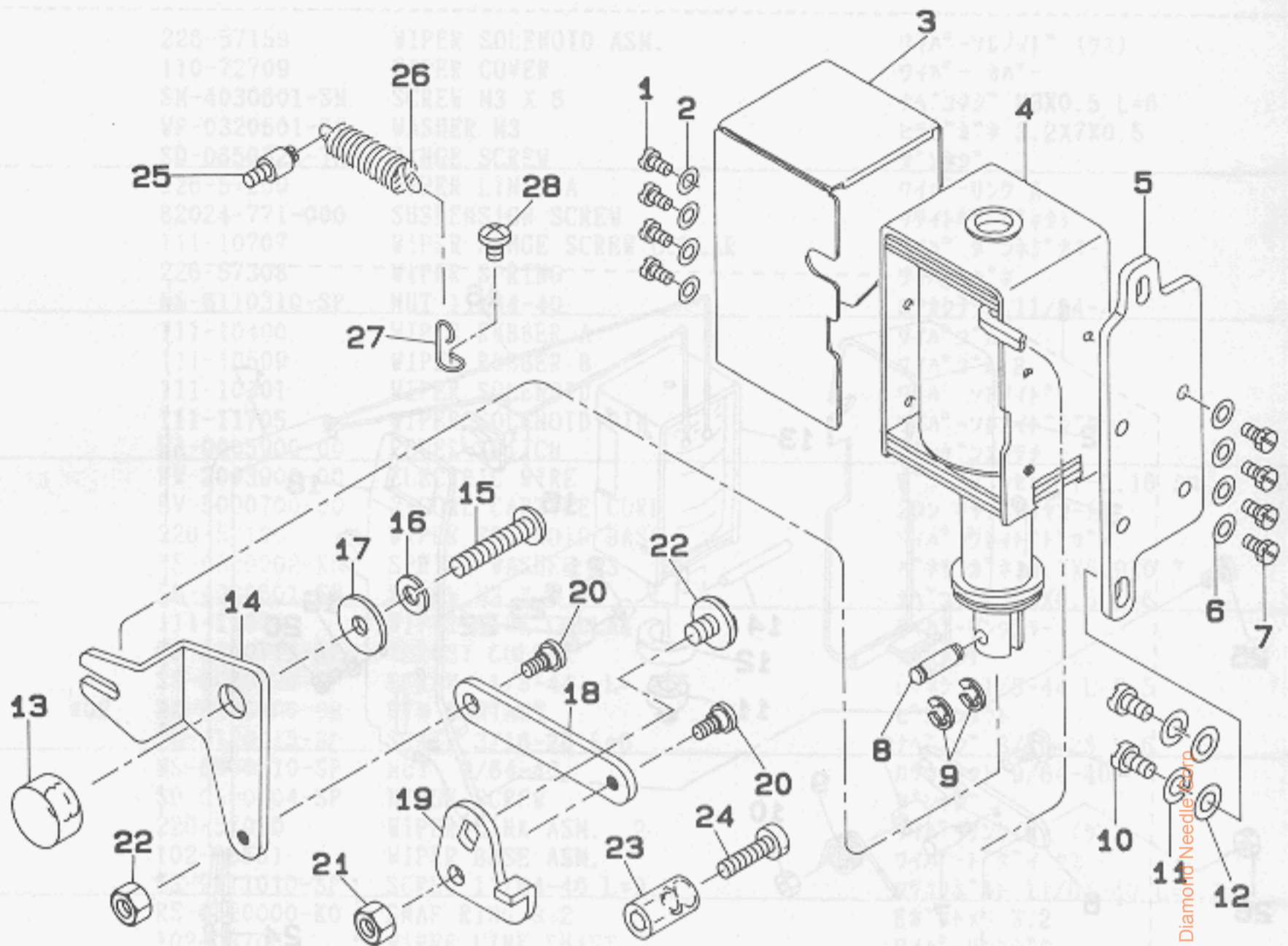

REF.NO	NOTE	PART NO.	DESCRIPTION	ヒンメイ	Qty
1	#01	SS-7110710-SP	SCREW 11/64-40 L=7	マルヒラネジ 11/64-40 L=7	4
2		WP-0501016-SD	WASHER 5X10.5X1	ヒラサカネ 5X10.5X1	4
3		101-61305	SOLENOID COVER	マグネットカバー	1
4		101-19105	REVERSE FEED SOLENOID, AC24V	キヤクオクリマグネット 24V	1
5		101-19204	SOLENOID INSTALLING PLATE	マグネットトリツケタイ	1
6		WP-0501016-SD	WASHER 5X10.5X1	ヒラサカネ 5X10.5X1	4
7		SS-9111010-SP	SCREW 11/64-40 L=9.5	ロツカクホルト 11/64-40 L=9.5	4
8		D2464-555-B00	LINK DRIVING MAGNET PIN	マグネット リンクピン	1
9		RE-0400000-K0	E-SHAPED SNAP RING (4MM)	Eカタメワ 4	1
10		SS-7151210-SP	SCREW 15/64-28 L=12	マルヒラネジ 15/64-28 L=12	2
11		WS-0631510-KP	SPRING WASHER	ハネサカネ	2
12		WP-0621016-SD	WASHER 6.2X13X1	ヒラサカネ 6.2X13X1	2
13		226-56409	LINK FULCULUM	Lカタリンクシデン	1
14		226-56300	REVERSE FEED LINK, L	ジャクオクリLカタリンク	1
15		SS-4153015-SP	PAN-SCREW 15/64-28 L=30	ナハネジ 15/64-28 L=30	1
16		WS-0610002-KP	SPRING WASHER	ハネサカネ	1
17		WP-0612056-SD	WASHER 6.1X18.5X2	ヒラサカネ 6.1X18.5X2	1
18		226-56201	REVERSE FEED LINK, (2)	ジャクオクリリンク (2)	1
19		226-56102	REVERSE FEED LINK, (1)	キヤクオクリリンク (1)	1
20		SD-0640326-TP	HINGE SCREW	タンネジ	2
21		NS-6110350-SP	NUT 11/64-40	ロツカクナツト 11/64-40	2
22		SS-7120760-SP	SCREW 3/16-28 L= 7.0	マルヒラネジ 3/16-28 L=7	1
23		111-00500	REVERSE FEED LEVER STOPPER	ハツクレハ- スツハ	1
24		SS-6121840-SP	SCREW 3/16-28 L=18.0	ヒラネジ 3/16-28 L=18	1
25		B1506-352-000	TENSION SPRING RACK B	ヒツハ°リ ハネカケ B	1
26		135-15606	SPRING	イトキリ ホジヨカム モトシハネ	1
27		226-56003	SPRING SUSPENSION	レハ-ハネカケ	1
28		SS-4120615-SP	SCREW 3/16-28 L=6	ナハネジ 3/16-28 L=6	1

From the library of: Diamond Needle Corp.

12. WIPER MECHANISM COMPONENTS
ワイパ装置関係

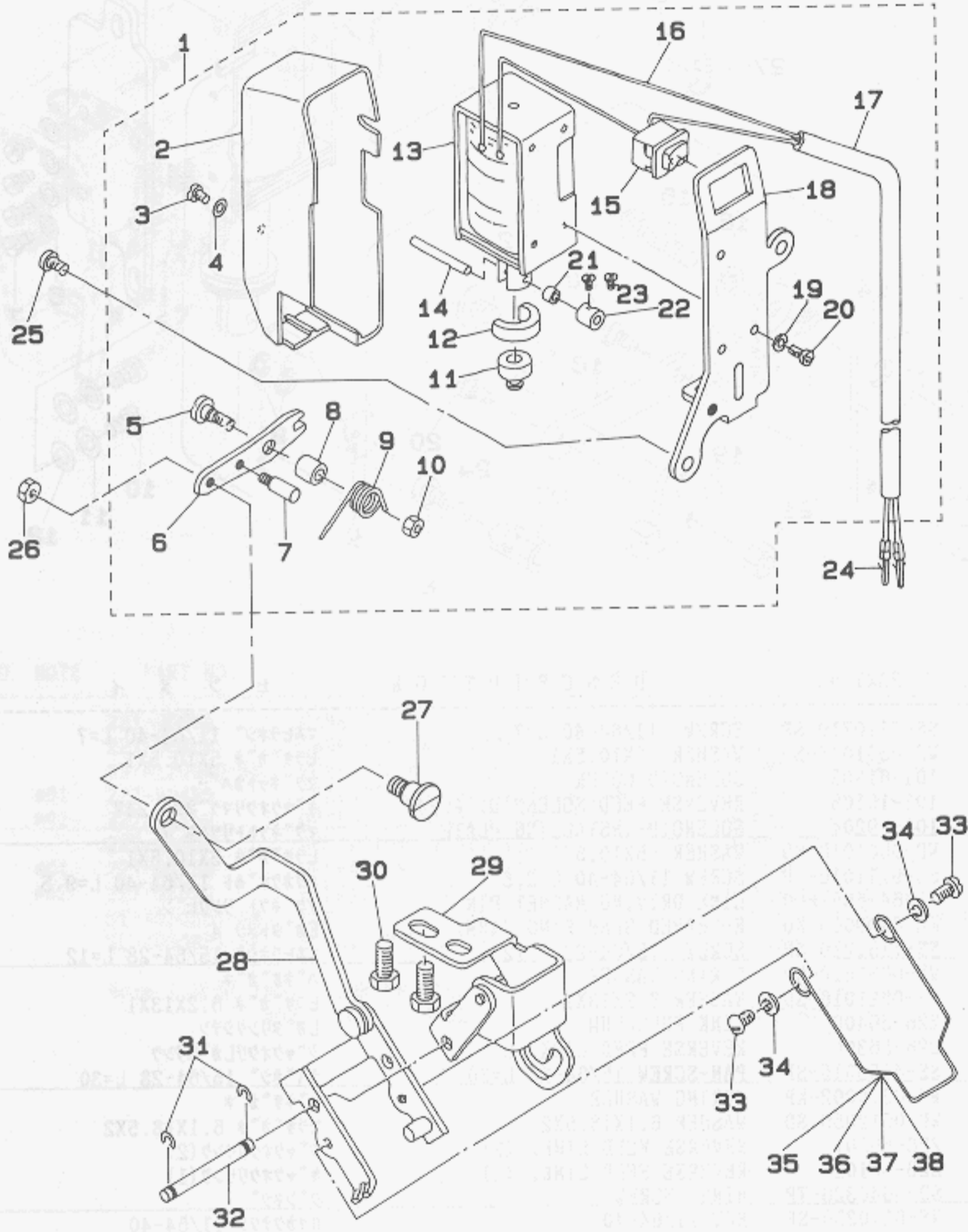

From the library of: Diamond Needle Corp

REF.NO	NOTE	PART NO.	DESCRIPTION	ヒンメイ	Qty
1		226-57159	WIPER SOLENOID ASM.	ワイパ-ソレノイド (クミ)	1
2		110-72709	WIPER COVER	ワイパ-カバー	(1)
3		SM-4030601-SM	SCREW M3 X 6	ナハコネジ M3X0.5 L=6	(1)
4		WP-0320501-SC	WASHER M3	ヒラサカネ 3.2X7X0.5	(1)
5		SD-0650321-TP	HINGE SCREW	タネネジ	(1)
6		226-57209	WIPER LINK, A	ワイパ-リンク A	(1)
7		B2024-771-000	SUSPENSION SCREW	ウワイトキリ ハネカケ	(1)
8		111-10707	WIPER HINGE SCREW COLLAR	ワイパ タネネジカラー	(1)
9		226-57308	WIPER SPRING	ワイパ-ハネ	(1)
10		NS-6110310-SP	NUT 11/64-40	ロツカクナツト 11/64-40	(1)
11		111-10400	WIPER RUBBER A	ワイパゴム A	(1)
12		111-10509	WIPER RUBBER B	ワイパゴム B	(1)
13		111-10301	WIPER SOLENOID	ワイパ ソレノイド	(1)
14		111-11705	WIPER SOLENOID PIN	ワイパ-ソレノイドシク	(1)
15		HA-0005900-00	POWER SWITCH	デッケンスイッチ	(1)
16		HW-2003900-00	ELECTRIC WIRE	ヒニルデッケン 17-0.16 シロ	(0.1)
17		HW-5000700-00	2-CORE CABTYRE CORD	2シン キヤブタイヤコード	(1.4)
18		226-57100	WIPER SOLENOID BASE	ワイパ-ソレノイドベース	(1)
19		WS-0310002-KN	SPRING WASHER M3	ハネサカネ 3.1X5.9X0.7	(3)
20		SM-4030601-SM	SCREW M3 X 6	ナハコネジ M3X0.5 L=6	(3)
21		111-11804	WIPER LINK COLLAR	ワイパ-リンクカラー	(1)
22		CS-0300711-SP	THRUST COLLAR	スラストウケ	(1)
23		SS-6080320-SP	SCREW 1/8-44 L= 2.5	ヒラネジ 1/8-44 L=2.5	(2)
24	#02	HK-0346400-0B	PIN CONTACT	ピンコンタクト	2
25		SS-4120615-SP	SCREW 3/16-28 L=6	ナハネジ 3/16-28 L=6	1
26		NS-6090310-SP	NUT 9/64-40	ロツカクナツト 9/64-40	1
27		SD-0500404-SP	HINGE SCREW	タネネジ	1
28		226-57050	WIPER LINK ASM., 2	ワイパ-リンク(2) (クミ)	1
29		102-08551	WIPER BASE ASM.	ワイパ-ベースクミ	1
30		SS-9111010-SP	SCREW 11/64-40 L=9.5	ロツカクホルト 11/64-40 L=9.5	2
31		RE-0320000-KO	SNAP RING 3.2	Eカトメリ 3.2	2
32		102-08700	WIPER LINK SHAFT	ワイパ-リンクシク	1
33		SS-3090520-SP	SCREW 9/64-40 L=4.5	マルネジ 9/64-40 L=4.5	2
34		WP-0371016-SD	WASHER 3.7X8X1	ヒラサカネ 3.7X8X1	2
35	#01	102-09203	WIPER 3/32"-3/8"	ワイパ-	1
36	#01	102-09500	WIPER	ワイパ-	1
37	#01	102-09807	WIPER	ワイパ-	1
38	#01	102-09906	WIPER	ワイパ-	1

Note (注記) #01...SELECTIVE PART
#02...FOR LH-3162-7

選択部品
LH-3162-7 用

From the library of: Diamond Needle Co.

13. LUBRICATION COMPONENTS
給油関係

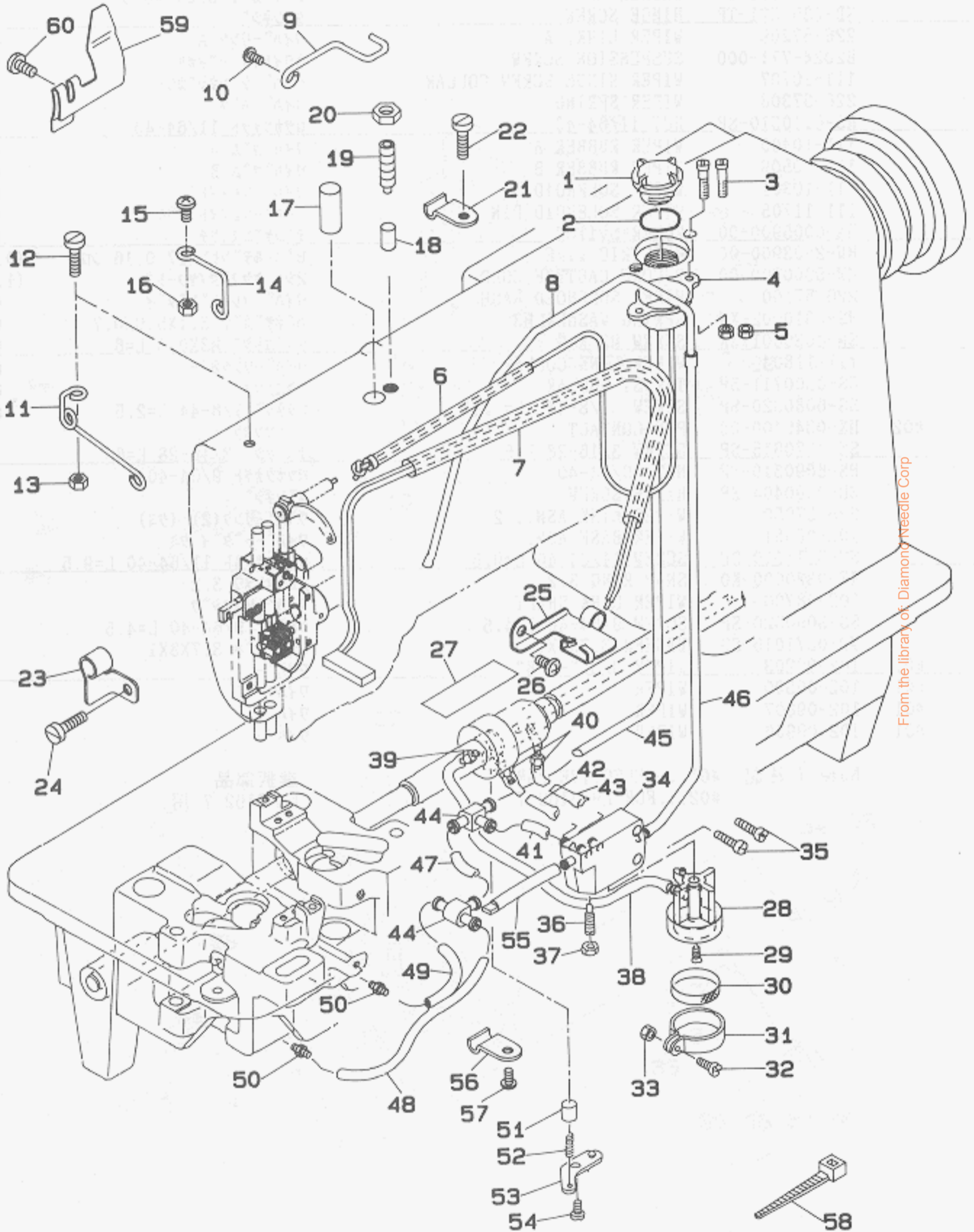

From the library of: Diamond Needle Corp

REF.NO	NOTE	PART NO.	DESCRIPTION	ヒンメイ	Qty
1		B3530-555-000	OIL SIGHT WINDOW	アブラマト	1
2		RO-1952401-00	RUBBER RING	Oリング	1
3		SS-4111815-SP	SCREW	ナメネジ 11/64-40 L=18	2
4		102-16703	OIL TANK	オイルタンク	1
5		NS-6110310-SN	NUT 11/64-40	ロツカクナツト 11/64-40	2
6		226-20355	OIL PIPE ASM.	メンブキユウユハ°イフ°(クミ)	1
7		226-20454	FELT ASM.	カンリュウフエルト(クミ)	1
8		226-20702	OIL TUBE	キユウユカン	1
9		226-20108	PIPE HOLDER, B	カンリュウハ°イフ°オサI B	1
10		SS-4110715-SP	SCREW 11/64-40 L=7	ナメネジ 11/64-40 L=7	1
11		226-19209	OIL WICK GUIDE	メンブユジンカ°イト	1
12		SS-6121610-SP	SCREW 3/16-28 L=15.5	ヒラネジ 3/16-28 L=15.5	1
13		NS-6120310-SP	NUT 3/16-28	ロツカクナツト 3/16-28	1
14		226-20504	OIL WICK HOLDER	メンブキユウユジンササI	1
15		SS-4111215-SP	SCREW 11/64-40 L=12	ナメネジ 11/64-40 L=12	1
16		NS-6110430-SP	NUT 11/64-40	ロツカクナツト 11/64-40	1
17		226-19308	OIL ADJUSTING FELT	メンブキユウユチョウセツフエルト	1
18		226-19407	OIL ADJUSTING SHAFT	メンブユリョウチョウセツシク	1
19		SS-8701782-TP	SCREW 5/16-24 L=17.0	トメネジ 5/16-24 L=17	1
20		NS-6700420-SP	NUT 5/16-24	ロツカクナツト 5/16-24	1
21		226-20801	PIPE HOLDER	キユウユカンオサI	1
22		SS-6111610-SP	SCREW 11/64-40 L=16	ヒラネジ 11/64-40 L=16	1
23		226-20009	PIPE HOLDER	メンブカンリュウハ°イフ°オサI	1
24		SS-4110615-SP	SCREW 11/64-40 L=6	ナメコネジ	1
25		226-19803	VILENE HOLDER	カンリュウハ°イリ°ンササI	1
26		SS-4110715-SP	SCREW 11/64-40 L=7	ナメネジ 11/64-40 L=7	1
27		226-19605	VILENE	カンリュウハ°イリ°ン	1
28		226-19001	SUCTION	キユウユク°チ	1
29		SS-2110930-SP	SCREW 11/64-40 L=8.7	マルサラネジ 11/64-40 L=8.75	1
30		B1851-512-000	FILTER SCREEN	キユウユク°チ アミ	1
31		B1850-512-000	BUSHING HOLDER	キユウユク°チ カナク	1
32		SS-4090915-SP	SCREW 9/64-40 L=9	ナメネジ 9/64-40 L=9	1
33		NS-6090310-SP	NUT 9/64-40	ロツカクナツト 9/64-40	1
34		106-23403	BASE	アブララフ°ンハ°イタ°イ	1
35		SS-6111610-SP	SCREW 11/64-40 L=16	ヒラネジ 11/64-40 L=16	2
36		106-23601	OIL ADJUSTING SCREW	ユリョウ チョウセツネジ	1
37		NS-6110310-SP	NUT 11/64-40	ロツカクナツト 11/64-40	1
38		BT-0500300-EA	OIL TUBE	ウレタンチューブ	0.12
39		SQ-1150451-MZ	CONNECTING SCREW	チューブ°レンケツネジ	1
40		SQ-1110401-MZ	CONNECTING SCREW	チューブ°レンケツネジ	2
41		BT-0500300-EA	OIL TUBE	ウレタンチューブ	0.04
42		BT-0500300-EA	OIL TUBE	ウレタンチューブ	0.08
43		BT-0500300-EA	OIL TUBE	ウレタンチューブ	0.09
44		137-65607	OIL CONNEC. ARM	キユウユ レンケツウデ	2
45		BT-0500300-EA	OIL TUBE	ウレタンチューブ	0.47
46		BT-0500300-EA	OIL TUBE	ウレタンチューブ	0.4
47		BT-0500300-EA	OIL TUBE	ウレタンチューブ	0.03
48		BT-0500300-EA	OIL TUBE	ウレタンチューブ	0.21
49		BT-0500300-EA	OIL TUBE	ウレタンチューブ	0.15
50		SQ-1150451-MZ	CONNECTING SCREW	チューブ°レンケツネジ	2
51		B3534-155-000	PLUNGER	プ°ランジ°ヤ	1
52		B1214-038-000	PLUNGER SPRING	プ°ランジ°ヤ オサIハ°ネ	1
53		B3524-552-000	PLUNGER THRUST PLATE	プ°ランジ°ヤ オサIカナク	1
54		SS-4110815-SP	SCREW 11/64-40 L=8	ナメネジ 11/64-40 L=8	1
55		139-41307	OIL RETURN FELT PIPE	カンリュウフエルトハ°イフ°	1
56		B3538-112-000	CORD HOLDER	コト°オサI	1
57		SS-4110815-SP	SCREW 11/64-40 L=8	ナメネジ 11/64-40 L=8	1
58		EA-9500B01-00	CABLE BAND	ソクセンハ°ント	1
59		226-86307	OIL GUIDE	メンハ°ンキユウユカ°イト°S	1
60		SS-7090610-SP	SCREW 9/64-40 L=6	マルヒラネジ 9/64-40 L=6	1

From the library of Diamonneedle Corp.

14. OIL RESERVOIR & KNEE LIFTER COMPONENTS

油溜・膝上げ関係

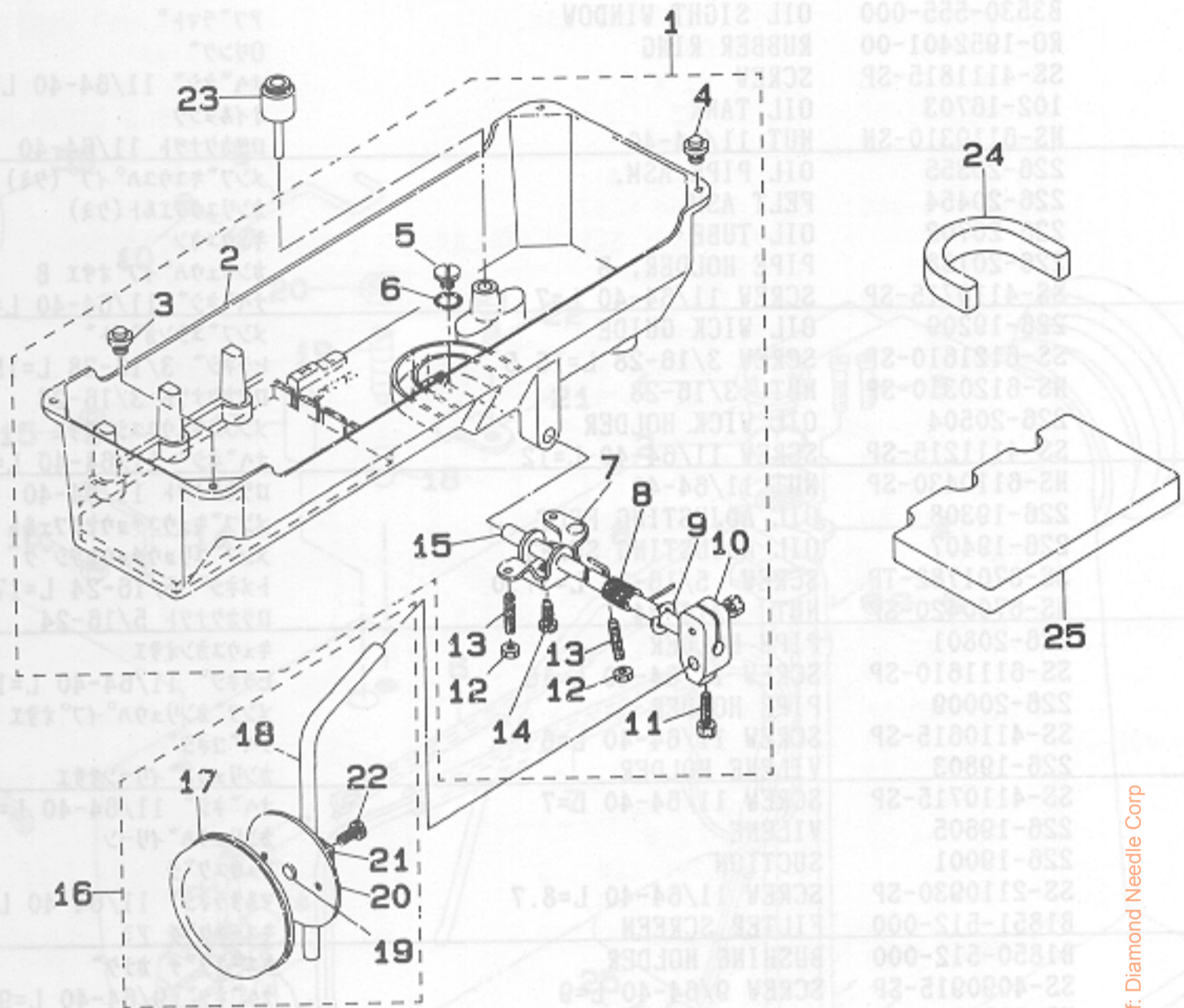

REF.NO	NOTE	PART NO.	DESCRIPTION	ヒソメイ	Qty
1		101-62253	OIL RESERVOIR ASM.	アブラタマリ(ケミ)	1
2		101-62204	OIL RESERVOIR	アブラタマリ	(1)
3		101-62600	RUBBER CUSHION	トウワササゴム	(2)
4		110-47107	RUBBER CUSHION	トウワササゴム	(2)
5		SS-6700710-SH	SCREW	ヒラネジ	(1)
6		RO-0982401-00	RUBBER RING	リング	(1)
7		110-24007	CONNECTING ROD, VERTICAL	ヒサアケ カイテンウデ	(1)
8		110-24106	SPRING	ヒサアケ カイテンハネ	(1)
9		RE-1000000-K0	E-RING	Eカタメワ	(1)
10		110-24502	KNEE PRESS LOD BEARING BRACKET	ヒサアテタテシクトリツケウデ	(1)
11		SS-9182010-SN	SCREW 9/32-20 L=20	ロツカクホルト 9/32-20 L=20	(2)
12		NS-6150430-SR	NUT 15/64-28	ロツカクナツト 15/64-28	(2)
13		SS-8153010-SR	SCREW 15/64-28 L=30	トメネジ 15/64-28 L=30	(2)
14		SS-9151810-SR	SCREW	ロツカクホルト	(1)
15		110-24205	KNEE PRESS ROD	ヒサアテヨコシク	(1)
16		110-23751	KNEE PRESS PLATE ASM.	ヒサアテイタ クミ	1
17		B3431-552-000-A	KNEE PRESS PLATE COVER	ヒサアテイタ カハ-	(1)
18		B3419-122-000	KNEE LIFTER PLATE ROD	ヒサアテ タテシク	(1)
19		110-24403	RUBBER	ヒサアテ ゴム	(1)
20		110-23702	KNEE PRESS PLATE	ヒサアテイタ	(1)
21		110-23801	KNEE PRESS PLATE HOLDER	ヒサアテイタササエ	(1)
22		SS-9151540-SR	SCREW 15/64-28 L=15	ロツカクホルト 15/64-28 L=15	(1)
23		110-24304	KNEE PRESS LIFTER ROD	ヒサアケ オシホウ	1
24		226-22005	OIL RESERVOIR SPACER, A	アブラタマリサ A	1
25		226-22104	OIL RESERVOIR SPACER, B	アブラタマリサ B	1

From the library of: Diamond Needle Corp

15. BELT COVER & BOBBIN WINDER COMPONENTS
 ベルトカバー・糸巻き装置関係

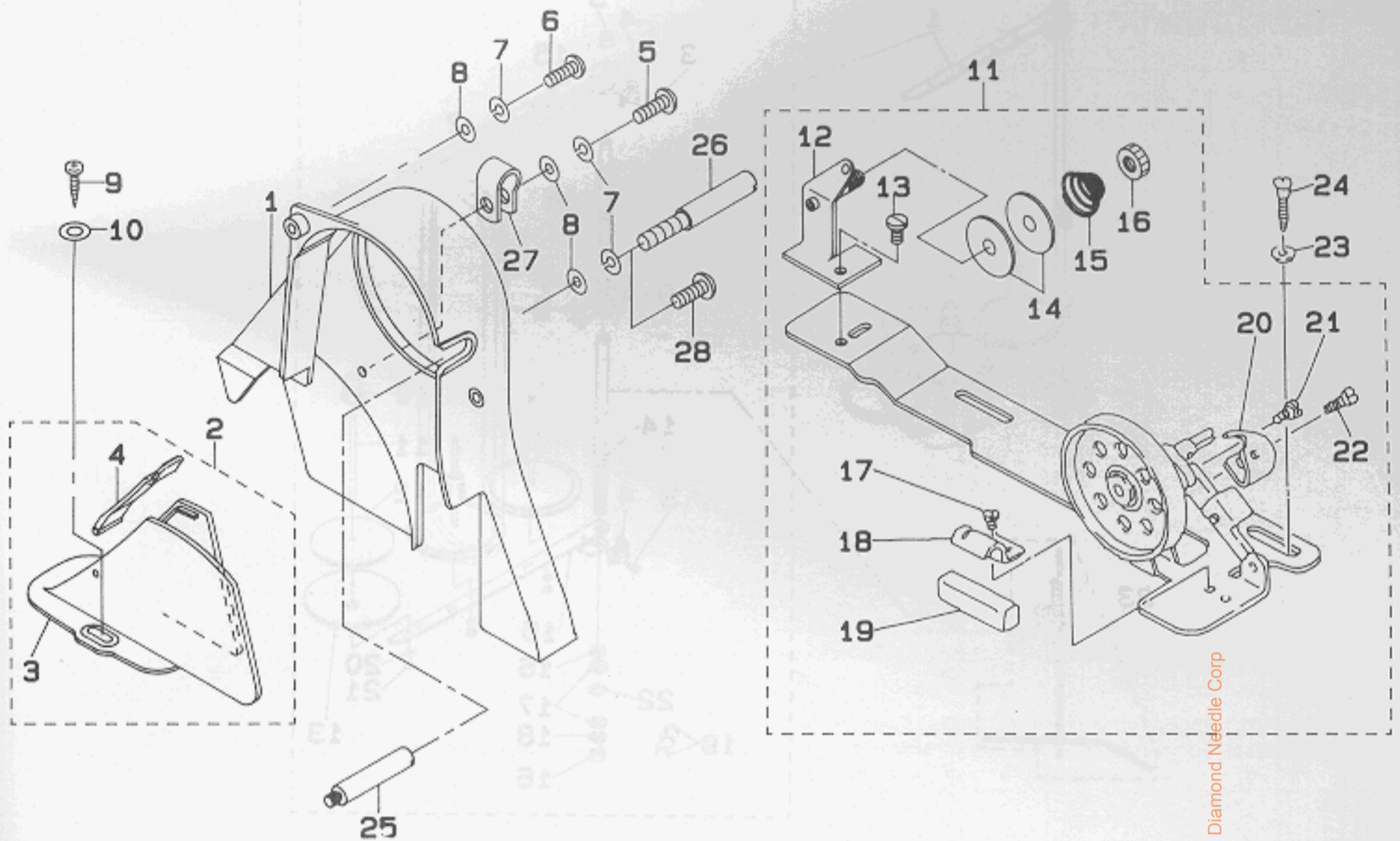

REF.NO	NOTE	PART NO.	DESCRIPTION	ヒ	ソ	メ	イ	Qty	
1		226-03401	BELT COVER A ASM.	ベルトカバー	A			1	
2		226-51350	BELT COVER B ASM.	ベルトカバー	B	(イキリツキ)	クミ	1	
3		226-51301	BELT COVER B	ベルトカバー	B	(イキリツキ)		(1)	
4		110-76957	BELT COVER B CAP ASM.	ベルトカバー	B	フタ	クミ	(1)	
5		SS-4111215-SP	SCREW 11/64-40 L=12	ナベネジ	11/64-40	L=12		1	
6		SS-4121615-SP	SCREW 3/16-28 L=16	ナベネジ	3/16-28	L=16		1	
7		WS-0451040-KP	SPRING WASHER 4.5X8.5X1	ハネサカネ	4.5X8.5X1			3	
8		WP-0501016-SD	WASHER 5X10.5X1	ヒラサカネ	5X10.5X1			3	
9		SK-3412000-SC	WOOD SCREW D=4.1 L=20	マルモクネジ	D=4.1	L=20		2	
10		WP-0450826-SC	WASHER 4.5X10X0.8	ヒラサカネ	4.5X10X0.8			2	
11		110-77567	BOBBIN WINDER COMPL.	イトマキソウチ	ケツコウ			1	
12		110-78250	THREAD TENSION BRACKET ASM.	イトマキイトチヨウシホ	ウタ	イ	ケツコウ	(1)	
13		SS-7110840-SP	SCREW 11/64-40 L=7.8	マルヒラネジ	11/64-40	L=7.8		(1)	
14		B3126-012-000	THREAD TENSION DISK	イトチヨウシガラ				(2)	
15		B3129-012-B00	THREAD TENSION SPRING	イトチヨウシ	ハネ	B		(1)	
16		110-72204	TENSION NUT	イトチヨウシ	ナット			(1)	
17		SS-7110350-SP	SCREW 11/64-40 L=3.5	マルヒラネジ	11/64-40	L= 3.5		(1)	
18		110-78102	PRESSER PLATE	セイトウゴム	オサエ	イ	イ	(1)	
19		B3211-555-000	RUBBER BRAKE	セイト	ゴム			(1)	
20		110-78003	POSITIONING FINGER	ホヒン	オサエ			(1)	
21		SD-0490261-SP	HINGE SCREW D=4.9 H=2.6	タンネジ	D=4.9	H=2.6		(1)	
22		SS-7081310-SP	SCREW 1/8-44 L=12.5	マルヒラネジ	1/8-44	L=12.5		(1)	
23		WP-0450826-SC	WASHER 4.5X10X0.8	ヒラサカネ	4.5X10X0.8			2	
24		SK-3412000-SC	WOOD SCREW D=4.1 L=20	マルモクネジ	D=4.1	L=20		2	
25		B8233-555-000	BELT COVER SUPPORT STUD	ベルト	カバー	シチュウ		2	
26	#01	227-90505	SENSOR SUPPORT SHAFT B	ケンシュウキ	サシ	イ	ク	B	1
27	#01	D2120-555-C00	CORD PRESSER (120V)	ナイロン	クランプ			1	
28	#02	SS-4111215-SP	SCREW 11/64-40 L=12	ナベネジ	11/64-40	L=12		1	

Note (注記) #01...FOR LH-3162-4
 #02...FOR LH-3162-7

LH-3162-4 用
 LH-3162-7 用

16. THREAD STAND COMPONENTS
糸立装置関係

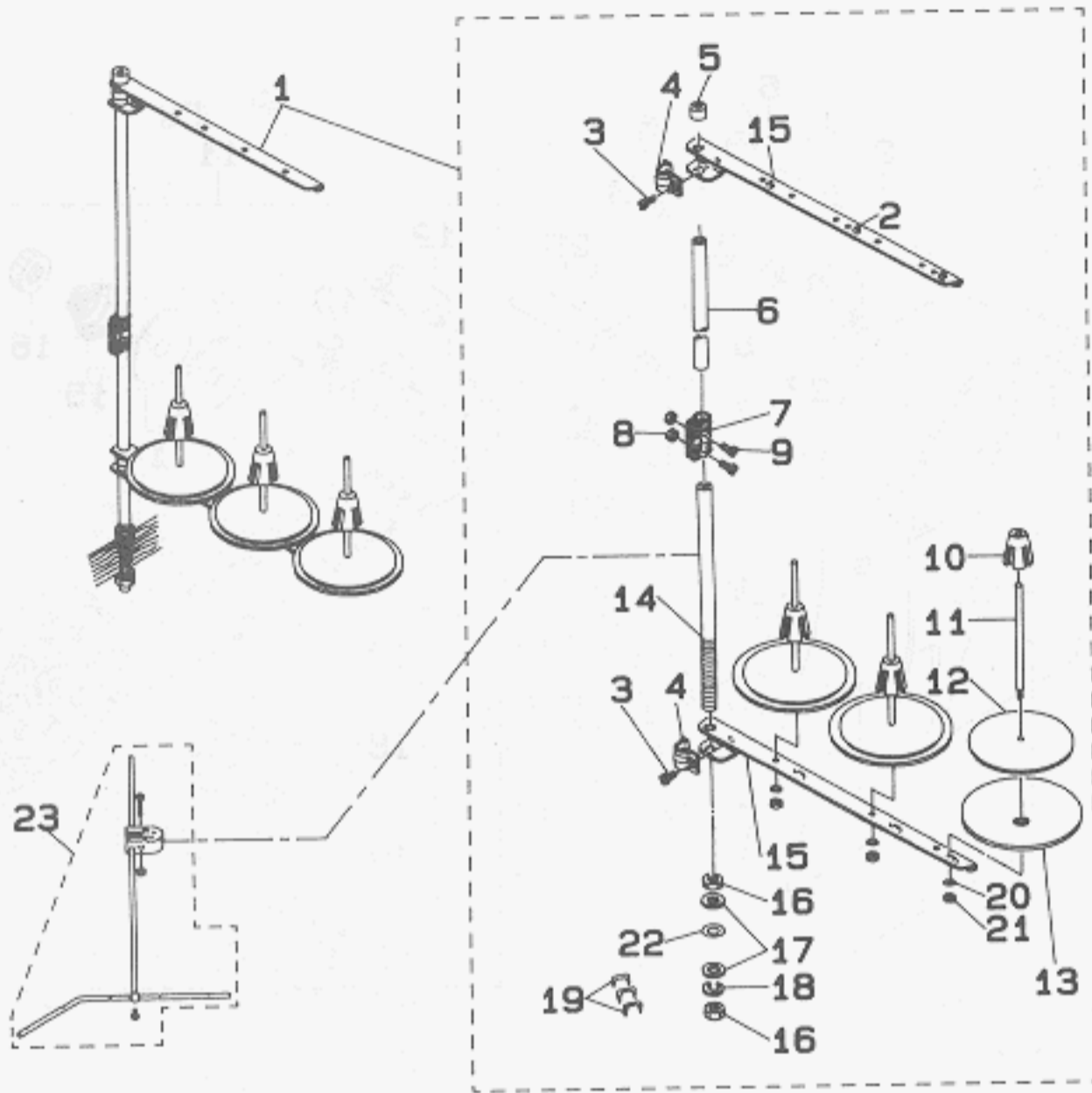

REF.NO	NOTE	PART NO.	DESCRIPTION	ヒソメイ	Qty
1		226-21551	THREAD STAND ASM.	イトタテソウチ(クミ)	1
2		B3319-704-L00	THREAD GUIDE	イトミチ	(3)
3		SM-6061610-SC	SCREW M6 L=16	ヒラコネジ M6 L=16	(2)
4		B3318-704-L00-A	THREAD GUIDE ARM JOINT	イトタテウデ シメカナク	(2)
5		111-84108	SPOOL REST ROD RUBBER CAP	イトタテホウ ホココム	(1)
6		111-83704	SPOOL REST ROD, UPPER	イトタテホウ (ウエ)	(1)
7		B3305-704-000-A	SPOOL REST ROD JOINT	イトタテホウ ツキテ	(1)
8		NM-6050001-SE	NUT M5X0.8	ロツカクナツト M5X0.8 1シユ	(2)
9		SM-4051405-SE	SCREW M5X0.8 L=14	ナハコネジ M5X0.8 L=14	(2)
10		111-84009	SPOOL RETAINER	イトマキ フレトメ	(3)
11		B3320-704-L00-A	SPOOL PIN	イトマキウケホウ	(3)
12		B3311-012-000	SPOOL REST CUSHION	イトマキウケサ	(3)
13		111-83902	SPOOL REST	イトマキ ウケサラ	(3)
14		111-83605	SPOOL REST ROD, LOWER	イトタテホウ (シタ)	(1)
15		119-57602	THREAD GUIDE ARM, A	イトタテウデ (A)	(2)
16		B3317-704-000	NUT C15	イトタテホウ トメナツト	(2)
17		WP-1702600-S0	WASHER 17X30X2.6	ヒラサカネ 17X30X2.6	(2)
18		WS-1643202-KR	SPRING WASHER	ハネサカネ 16.4X26.6X3.2	(1)
19		MAO-11532000	CORD STAPLE	コート ステツブ	(3)
20		WS-0510002-KN	SPRING WASHER	ハネサカネ 5.1X9.2X1.3	(3)
21		NM-6050001-SE	NUT M5X0.8	ロツカクナツト M5X0.8 1シユ	(3)
22		D3310-555-D00	RUBBER WASHER	イトタテホウ ホコシヨム	(1)
23		B3309-704-0A0	THREAD GUIDE ARM ASM.	イトタテ イアンナイ ウデ クミ	1

From the library of: Diamond Needle Corp

17. MOTOR PULLEY COMPONENTS
 モータープーリー関係

TABLE OF EXCHANGING GAUGE PARTS
 交換部品表

PART NO.	品名	QTY	UNIT	REMARKS
BT-0500300-00	Motor Pulley	1	EA	
BT-0500300-01	Motor Pulley	1	EA	
BT-0500300-02	Motor Pulley	1	EA	
BT-0500300-03	Motor Pulley	1	EA	
BT-0500300-04	Motor Pulley	1	EA	
BT-0500300-05	Motor Pulley	1	EA	
BT-0500300-06	Motor Pulley	1	EA	
BT-0500300-07	Motor Pulley	1	EA	
BT-0500300-08	Motor Pulley	1	EA	
BT-0500300-09	Motor Pulley	1	EA	
BT-0500300-10	Motor Pulley	1	EA	
BT-0500300-11	Motor Pulley	1	EA	
BT-0500300-12	Motor Pulley	1	EA	
BT-0500300-13	Motor Pulley	1	EA	
BT-0500300-14	Motor Pulley	1	EA	
BT-0500300-15	Motor Pulley	1	EA	
BT-0500300-16	Motor Pulley	1	EA	
BT-0500300-17	Motor Pulley	1	EA	
BT-0500300-18	Motor Pulley	1	EA	
BT-0500300-19	Motor Pulley	1	EA	
BT-0500300-20	Motor Pulley	1	EA	
BT-0500300-21	Motor Pulley	1	EA	
BT-0500300-22	Motor Pulley	1	EA	
BT-0500300-23	Motor Pulley	1	EA	
BT-0500300-24	Motor Pulley	1	EA	
BT-0500300-25	Motor Pulley	1	EA	
BT-0500300-26	Motor Pulley	1	EA	
BT-0500300-27	Motor Pulley	1	EA	
BT-0500300-28	Motor Pulley	1	EA	
BT-0500300-29	Motor Pulley	1	EA	
BT-0500300-30	Motor Pulley	1	EA	
BT-0500300-31	Motor Pulley	1	EA	
BT-0500300-32	Motor Pulley	1	EA	
BT-0500300-33	Motor Pulley	1	EA	
BT-0500300-34	Motor Pulley	1	EA	
BT-0500300-35	Motor Pulley	1	EA	
BT-0500300-36	Motor Pulley	1	EA	
BT-0500300-37	Motor Pulley	1	EA	
BT-0500300-38	Motor Pulley	1	EA	
BT-0500300-39	Motor Pulley	1	EA	
BT-0500300-40	Motor Pulley	1	EA	
BT-0500300-41	Motor Pulley	1	EA	
BT-0500300-42	Motor Pulley	1	EA	
BT-0500300-43	Motor Pulley	1	EA	
BT-0500300-44	Motor Pulley	1	EA	
BT-0500300-45	Motor Pulley	1	EA	
BT-0500300-46	Motor Pulley	1	EA	
BT-0500300-47	Motor Pulley	1	EA	
BT-0500300-48	Motor Pulley	1	EA	
BT-0500300-49	Motor Pulley	1	EA	
BT-0500300-50	Motor Pulley	1	EA	

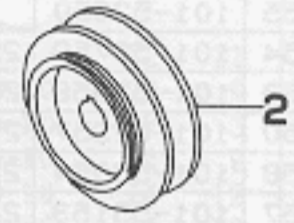
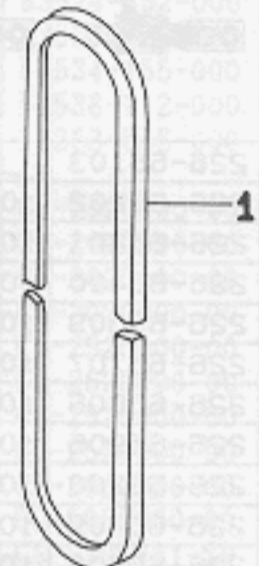







REF. NO	NOTE	PART NO.	DESCRIPTION	ヒ	ソ	メ	イ	Qty
1	#01	MTJ-VH00400A	V-BELT, 40 INCH					1
2	#01	MTS-P00800B0	MOTOR PULLEY ASM. 80					1

Note (注記) #01...FOR LH-3162-7



LH-3162-7 用

From the library of: Diamond Needle Corp

18. TABLE OF EXCHANGING GAUGE PARTS
交換ゲージ部品一覧表

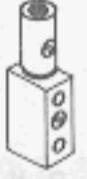
Needle gauge size 針 幅		Presser Foot asm. 押 さ え (組)			Throat plate with Thread Trimmer 針板 (糸切付)	Feed dog (with Thread Trimmer) 送り歯 (糸切付)		
Code コード	inch mm							
	inch	mm						
B	1/8	3.2	226-37656		226-60203	226-65103		
C	5/32	4.4	226-37755	101-52650	226-60302	226-65202	102-37907	
D	3/16	4.8	226-37854	101-52759	226-40353	226-60401	226-65301	102-38004 102-39101
E	7/32	5.6	226-37953	101-52858	226-40452	226-60500	226-65400	102-38103 102-39200
F	1/4	6.4	226-38050	101-52957	226-40551	226-60609	226-65509	102-38202 102-39309
G	9/32	7.1	226-38258	101-53054	226-40759	226-60708	226-65707	102-38301 102-39408
H	5/16	7.9	226-38357	101-53153	226-40858	226-60807	226-65806	102-38400 102-39507
K	3/8	9.5	226-38456	101-53252	226-40957	226-60906	226-65905	102-38509 102-39606
L	1/2	12.7	226-38753	101-53450	226-41252	226-61102	226-66200	102-38707 102-39804
M	5/8	15.9	226-38852	101-53559	226-41351	226-61201	226-66309	102-38806 102-39903
N	3/4	19.1	226-38951	101-53658	226-41450	226-61300	226-66408	102-38905 101-71106
Q	1	25.4	226-39256	101-53856	226-41757	226-61508	226-66705	102-39002 101-71304
Stitch spec. 縫 仕 様	S			★	☆	Spec. common		★
	A		★			仕様共通	★	
	G			☆	★			★

Needle gauge size 針 幅		Needle clamp asm. Left 針 管 (組) 左	Needle clamp asm. Right 針 管 (組) 右
Code コード	inch mm		
	inch	mm	
B	1/8	3.2	B1402-528-BA0-A
C	5/32	4.4	B1402-528-CA0-A
D	3/16	4.8	B1402-528-DAL-A
E	7/32	5.6	B1402-528-EAL
F	1/4	6.4	B1402-528-FAL
G	9/32	7.1	B1402-528-GAL
H	5/16	7.9	B1402-528-HAL-A
K	3/8	9.5	B1402-528-KAL-A
L	1/2	12.7	B1402-528-LAL
M	5/8	15.9	B1402-528-MAL
N	3/4	19.1	B1402-528-NAL
Q	1	25.4	B1402-528-QAL
Stitch spec. 縫 仕 様	S		Spec. common 仕様共通
	A		
	G		

Needle gauge size 針 幅		Bed slide asm. (with thread trimmer) 送り板 (組) (糸切り付)		
Code コード	inch mm		Bed Slide asm. (Left) 糸切り送り板 (左) 組	Bed Slide asm. (Right) 糸切り送り板 (右) 組
	inch	mm		
B	1/8	3.2		
C	5/32	4.4	226-50857	226-50352
D	3/16	4.8		
E	7/32	5.6		
F	1/4	6.4		
G	9/32	7.1		
H	5/16	7.9		
K	3/8	9.5		
L	1/2	12.7		
M	5/8	15.9	226-50956	226-50451
N	3/4	19.1		
Q	1	25.4	226-51053	226-50550

- ★ Standard spec. 標準仕様
- ☆ Substandard spec. 準標準仕様
- * Special order 特別注文

From the library of Diamond Needle Corp

NUMERICAL INDEX OF PARTS

索引

PART NO 品番	PAGE 頁	REF NO	PART NO 品番	PAGE 頁	REF NO	PART NO 品番	PAGE 頁	REF NO	PART NO 品番	PAGE 頁	REF NO
BT-0500300-EA	24	38	B3319-704-L00	27	2	NS-6110420-SP	10	46	SS-4110715-SP	24	10
BT-0500300-EA	24	41	B3320-704-L00-A	27	11	NS-6110430-SP	24	16	SS-4110715-SP	24	26
BT-0500300-EA	24	42	B3417-051-000	16	62	NS-6120310-SP	24	13	SS-4110815-SP	2	1
BT-0500300-EA	24	43	B3418-180-000	16	17	NS-6150430-SP	6	34	SS-4110815-SP	10	58
BT-0500300-EA	24	45	B3419-122-000	25	18	NS-6150430-SR	25	12	SS-4110815-SP	12	23
BT-0500300-EA	24	46	B3431-552-000-A	25	17	NS-6620310-SP	14	26	SS-4110815-SP	24	54
BT-0500300-EA	24	47	B3524-552-000	24	53	NS-6680320-SP	12	55	SS-4110815-SP	24	57
BT-0500300-EA	24	48	B3530-555-000	24	1	NS-6700420-SP	24	20	SS-4111215-SP	14	30
BT-0500300-EA	24	49	B3534-155-000	24	51				SS-4111215-SP	24	15
B1104-051-000	2	29	B3538-112-000	24	56	PS-0300201-KP	16	25	SS-4111215-SP	26	5
B1131-057-000	2	27	B8233-555-000	26	25	PS-0600502-KP	14	34	SS-4111215-SP	26	28
B1148-555-000	12	18				PT-0502700-SO	6	13	SS-4111815-SP	24	3
B1202-512-000	4	13	CQ-2020000-00	4	3				SS-4120615-SP	2	6
B1214-019-000	4	14	CQ-2020000-00	6	3	RE-0320000-KO	22	31	SS-4120615-SP	2	8
B1214-038-000	24	52	CQ-2020000-00	10	43	RE-0400000-KO	20	9	SS-4120615-SP	8	39
B1402-528-FAL-A	6	45	CQ-2020000-00	10	47	RE-0500000-KO	12	3	SS-4120615-SP	20	28
B1402-528-FAR-A	6	54	CQ-2520000-00	4	4	RE-0500000-KO	14	9	SS-4120615-SP	22	25
B1416-528-000	6	43	CQ-2520000-00	4	7	RE-0500000-KO	14	12	SS-4121015-SP	2	19
B1416-528-000	6	52	CQ-2520000-00	6	73	RE-0500000-KO	14	18	SS-4121615-SP	26	6
B1422-512-000	6	9	CQ-2520000-00	12	64	RE-0500711-KP	12	38	SS-4153015-SP	20	15
B1425-526-000	6	44	CQ-3030000-00	12	65	RE-0900000-KO	12	13	SS-5090610-SP	2	28
B1425-526-000	6	46	CQ-5050000-00	4	11	RE-1000000-KO	25	9	SS-5090610-SP	16	9
B1425-526-000	6	53	CS-0300711-SP	22	22	RO-0371801-00	14	3	SS-6060510-TP	6	2
B1425-526-000	6	55	CS-070081B-SH	16	33	RO-0922702-00	12	16	SS-6060510-TP	6	22
B1438-512-800	6	28	CS-102121A-SH	12	10	RO-0982401-00	25	6	SS-6080320-SP	22	23
B1501-581-000	14	39	CS-1470710-SH	16	29	RO-1952401-00	24	2	SS-6080340-SP	6	66
B1502-541-000	14	42	CS-1471012-SH	10	16	RO-4372002-00	4	32	SS-6081810-SP	12	43
B1505-227-T00-A	14	38	CS-1471012-SH	12	50				SS-6090630-SP	2	34
B1505-804-000	18	21	CS-147121B-SH	12	48	SB-1200001-00	4	31	SS-6090670-TP	12	1
B1506-352-000	20	25				SB-3095301-0C	10	50	SS-6090810-SP	10	36
B1510-227-000	14	37	D2112-555-B00	2	5	SD-0470281-SP	8	7	SS-6110480-SP	10	66
B1515-051-000	16	46	D2120-555-C00	26	27	SD-0490261-SP	26	21	SS-6111140-SP	2	4
B1521-555-000	14	2	D2427-555-B00-B	16	42	SD-0500404-SP	22	27	SS-6111210-SP	4	23
B1603-512-000	12	44	D2428-555-B00-A	16	41	SD-0600271-SP	16	19	SS-6111610-SP	24	22
B1604-012-000-A	12	39	D2430-555-B00	16	39	SD-0600281-TP	18	4	SS-6111610-SP	24	35
B1610-512-000	12	30	D2464-555-B00	20	8	SD-0600322-SD	14	17	SS-6120940-SP	16	63
B1633-470-000	12	61	D3129-555-D00	8	19	SD-0640231-SP	18	9	SS-6120940-SP	19	3
B1636-581-B00	12	29	D3159-555-B00	14	25	SD-0640326-TP	20	20	SS-6121010-SP	18	13
B1653-470-000	12	63	D3163-555-B00-A	14	29	SD-0650305-TP	16	52	SS-6121212-TP	16	13
B1802-512-0A0-A	10	2	D3164-555-B00	14	27	SD-0650321-TP	22	5	SS-6121610-SP	18	14
B1803-515-0A0	10	10	D3171-415-B0H	10	62	SD-0720332-SP	14	14	SS-6121610-SP	24	12
B1816-512-000	10	4	D3310-555-D00	27	22	SD-0800422-CP	12	5	SS-6121610-TP	6	37
B1820-051-000	10	42				SD-0870601-SP	6	33	SS-6121610-TP	12	56
B1821-051-000	10	44	EA-9500B01-00	16	65	SD-0900701-TP	12	57	SS-6121610-TP	16	45
B1822-051-000	10	45	EA-9500B01-00	24	58	SK-3412000-SC	26	9	SS-6121610-TP	16	54
B1823-051-000	10	48				SK-3412000-SC	26	24	SS-6121840-SP	20	24
B1850-512-000	24	31	HA-0005900-00	22	15	SL-4030681-SC	18	28	SS-6121860-SP	12	21
B1851-512-000	24	30	HF-0041010-S0	18	32	SL-4030681-SC	18	30	SS-6151040-SP	16	58
B1853-512-00C-A	16	36	HK-0346101-40	16	57	SL-4030681-SC	18	34	SS-6151220-SP	16	38
B2024-771-000	22	7	HK-0346400-0B	16	56	SL-4030881-SF	19	10	SS-6151780-SP	2	14
B3041-980-000	16	59	HK-0346400-0B	22	24	SM-4030401-SC	18	27	SS-6152440-SP	6	32
B3112-704-000	8	21	HW-2003900-00	22	16	SM-4030601-SN	22	3	SS-6153040-SP	10	41
B3114-232-000	8	20	HW-5000700-00	22	17	SM-4030601-SN	22	20	SS-6560150-SH	10	29
B3125-012-000	8	23	HX-0005600-0B	18	33	SM-4051405-SE	27	9	SS-6580752-TP	12	31
B3125-527-000	8	24				SM-6061610-SC	27	3	SS-6661110-SP	4	15
B3126-012-000	8	16	MAO-11532000	27	19	SM-7082550-SP	10	69	SS-6661110-SP	12	26
B3126-012-000	26	14	MDP-500B1400	6	56	SQ-1110401-MZ	24	40	SS-6700710-SH	25	5
B3128-051-000	8	2	MTJ-VH00400A	28	1	SQ-1150451-MZ	24	39	SS-7060310-SP	6	58
B3128-527-000	8	31	MTS-P00800B0	28	2	SQ-1150451-MZ	24	50	SS-7081310-SP	26	22
B3129-012-A00	8	18	M4002-110-000	4	19	SS-2080810-SP	16	1	SS-7090520-SP	8	28
B3129-012-B00	26	15	M4007-110-0AA	4	20	SS-2090710-SP	2	24	SS-7090610-SP	24	60
B3132-552-000	8	17	M4007-110-0AB	4	21	SS-2090710-SP	2	33	SS-7090710-SP	16	12
B3137-527-0A0	8	32				SS-2090810-SP	2	26	SS-7090910-TP	14	44
B3138-527-000	8	29	NM-6030001-SC	18	35	SS-2110920-TP	2	35	SS-7110350-SP	26	17
B3139-527-000	8	33	NM-6040001-SD	18	18	SS-2110920-TP	16	27	SS-7110510-SP	12	60
B3140-527-000	8	30	NM-6050001-SE	27	8	SS-2110930-SP	16	28	SS-7110710-SP	6	19
B3141-527-000	8	25	NM-6050001-SE	27	21	SS-2110930-SP	24	29	SS-7110710-SP	10	71
B3142-527-000	8	34	NM-6050001-SP	16	43	SS-3090520-SP	22	33	SS-7110710-SP	12	27
B3143-527-000	8	35	NS-6080210-SP	12	42	SS-4080610-SP	6	27	SS-7110710-SP	20	1
B3211-555-000	26	19	NS-6090310-SP	22	26	SS-4090415-SP	6	4	SS-7110840-SP	26	13
B3214-047-000	8	11	NS-6090310-SP	24	33	SS-4090815-SP	6	16	SS-7110910-SP	12	51
B3305-704-000-A	27	7	NS-6110310-SN	24	5	SS-4090915-SP	24	32	SS-7111310-TP	12	45
B3309-704-0A0	27	23	NS-6110310-SP	8	8	SS-4110615-SP	8	37	SS-7120760-SP	4	42
B3311-012-000	27	12	NS-6110310-SP	22	10	SS-4110615-SP	24	24	SS-7120760-SP	10	15
B3317-704-000	27	16	NS-6110310-SP	24	37	SS-4110715-SP	14	28	SS-7120760-SP	20	22
B3318-704-L00-A	27	4	NS-6110350-SP	20	21	SS-4110715-SP	14	32	SS-7121410-SP	12	7

NUMERICAL INDEX OF PARTS

索引

PART NO 品番	PAGE 頁	REF NO	PART NO 品番	PAGE 頁	REF NO	PART NO 品番	PAGE 頁	REF NO	PART NO 品番	PAGE 頁	REF NO
SS-7151210-SP	20	10	WS-1643202-KR	27	18	110-24007	25	7	226-09309	12	54
SS-7151610-SP	16	16	WT-0530002-KS	2	9	110-24106	25	8	226-09408	12	41
SS-7681750-TP	4	36				110-24205	25	15	226-09606	12	53
SS-8080410-TP	8	27	101-01004	2	3	110-24304	25	23	226-09705	12	34
SS-8080610-SP	8	26	101-06102	12	46	110-24403	25	19	226-09754	12	33
SS-8080610-SP	16	7	101-07902	12	35	110-24502	25	10	226-09804	10	8
SS-8110410-TP	16	30	101-08009	12	12	110-32265	4	25	226-10000	12	6
SS-8110510-SP	16	34	101-08512	10	1	110-44054	2	7	226-10109	12	2
SS-8111010-TP	16	21	101-08611	10	11	110-45101	8	12	226-10208	12	4
SS-8120740-SP	2	22	101-09908	10	39	110-47107	25	4	226-10307	12	8
SS-8120740-SP	12	14	101-10500	10	25	110-52701	12	19	226-10406	12	22
SS-8151150-SP	10	3	101-10609	10	26	110-71602	14	35	226-10505	12	15
SS-8151150-SP	10	12	101-11201	10	49	110-71701	14	36	226-12303	10	33
SS-8151150-SP	12	47	101-11508	10	19	110-71800	14	1	226-12501	10	35
SS-8151150-TP	4	8	101-12001	10	6	110-71909	12	20	226-13251	10	51
SS-8151550-SP	4	22	101-12407	10	40	110-72204	26	16	226-13400	10	67
SS-8153010-SR	25	13	101-12803	10	32	110-72402	8	14	226-13509	10	38
SS-8620610-TP	12	40	101-12803	10	34	110-72709	22	2	226-13608	10	70
SS-8660530-TP	4	33	101-16051	16	3	110-76957	26	4	226-13707	10	13
SS-8660530-TP	10	7	101-16606	16	23	110-77567	26	11	226-15009	10	57
SS-8660530-TP	10	9	101-16705	16	40	110-78003	26	20	226-15108	10	56
SS-8660530-TP	10	17	101-16754	16	37	110-78102	26	18	226-15207	10	60
SS-8660530-TP	12	49	101-16804	16	15	110-78250	26	12	226-15306	10	59
SS-8660530-TP	12	62	101-16903	16	35	110-93606	8	13	226-15454	10	55
SS-8660610-TP	12	11	101-17109	16	24	111-00500	20	23	226-15702	10	61
SS-8660810-TP	10	5	101-17208	16	18	111-10301	22	13	226-15801	10	63
SS-8660810-TP	14	41	101-17851	16	55	111-10400	22	11	226-15959	10	64
SS-8660810-TP	16	32	101-19105	20	4	111-10509	22	12	226-17005	14	33
SS-8680540-SP	4	12	101-19204	20	5	111-10707	22	8	226-17104	14	22
SS-8680810-TP	4	37	101-24204	8	10	111-11705	22	14	226-18052	8	9
SS-8681650-TP	4	35	101-24303	8	15	111-11804	22	21	226-18060	8	1
SS-8701782-TP	24	19	101-25201	14	16	111-83605	27	14	226-18102	8	6
SS-9080410-SP	16	8	101-26654	10	65	111-83704	27	6	226-18201	8	4
SS-9110460-CP	2	31	101-52957	14	43	111-83902	27	13	226-18300	8	5
SS-9110460-CP	18	11	101-61305	20	3	111-84009	27	10	226-19001	24	28
SS-9111010-SP	16	50	101-62204	25	2	111-84108	27	5	226-19209	24	11
SS-9111010-SP	20	7	101-62253	25	1	113-06206	14	31	226-19308	24	17
SS-9111010-SP	22	30	101-62600	25	3	113-94509	14	23	226-19407	24	18
SS-9111820-SP	10	54	102-01200	2	10	119-56802	8	22	226-19605	24	27
SS-9151440-CP	12	36	102-08551	22	29	119-57602	27	15	226-19803	24	25
SS-9151540-SR	25	22	102-08700	22	32	135-15606	20	26	226-20009	24	23
SS-9151810-SR	25	14	102-09203	22	35	135-30209	2	17	226-20108	24	9
SS-9182010-SN	25	11	102-09500	22	36	137-65607	24	44	226-20355	24	6
ST-4030851-SN	19	9	102-09807	22	37	139-41307	24	55	226-20454	24	7
			102-09906	22	38				226-20504	24	14
TA-0750704-RO	2	13	102-10805	10	18	226-02007	2	15	226-20702	24	8
TA-1250406-RO	2	20	102-11407	16	6	226-02106	2	32	226-20801	24	21
TA-1250504-RO	2	11	102-11605	16	2	226-02601	2	40	226-21551	27	1
TA-1250504-RO	2	16	102-16703	24	4	226-03005	2	23	226-22005	25	24
TA-1270502-RO	2	12	102-38202	12	32	226-03104	2	25	226-22104	25	25
			103-15208	12	58	226-03401	26	1	226-22401	4	43
WP-0320501-SC	22	4	103-15455	12	59	226-03609	2	42	226-50055	2	39
WP-0371016-SD	10	37	103-15505	12	52	226-03708	2	43	226-50352	2	38
WP-0371016-SD	22	34	106-02902	2	2	226-03807	2	44	226-50857	2	36
WP-0450000-SD	6	18	106-04809	4	26	226-04003	4	38	226-51301	26	3
WP-0450801-SD	4	24	106-11457	10	14	226-04102	4	39	226-51350	26	2
WP-0450826-SC	26	10	106-23403	24	34	226-04300	4	40	226-51459	2	41
WP-0450826-SC	26	23	106-23601	24	36	226-04409	4	34	226-51509	4	18
WP-0501016-SD	8	38	106-97506	8	36	226-04607	4	30	226-51558	4	17
WP-0501016-SD	16	51	106-97605	8	3	226-04656	4	29	226-51566	4	16
WP-0501016-SD	16	64	107-41759	2	45	226-04706	4	27	226-51608	4	41
WP-0501016-SD	20	2	110-02904	6	6	226-04805	4	28	226-52002	12	25
WP-0501016-SD	20	6	110-06202	14	7	226-05109	4	2	226-52101	12	9
WP-0501016-SD	26	8	110-06350	14	6	226-05158	4	1	226-53000	10	30
WP-0612056-SD	20	17	110-06509	14	11	226-05208	4	6	226-53307	10	31
WP-0621016-SD	12	37	110-06756	14	4	226-06602	6	12	226-53505	10	53
WP-0621016-SD	18	5	110-07002	14	15	226-07006	6	31	226-53604	10	52
WP-0621016-SD	20	12	110-07101	14	13	226-07105	6	35	226-53802	10	20
WP-0850002-SP	10	68	110-07309	14	8	226-07204	6	36	226-54008	16	61
WP-1702800-SO	27	17	110-09909	12	17	226-07303	6	29	226-54107	16	31
WS-0310002-KN	18	26	110-18108	14	20	226-07402	6	30	226-54206	16	5
WS-0310002-KN	22	19	110-18207	14	19	226-08004	14	40	226-54255	16	4
WS-0451040-KP	26	7	110-18702	2	21	226-08103	14	10	226-54305	16	53
WS-0510002-KN	27	20	110-23702	25	20	226-08152	14	5	226-54404	16	44
WS-0610002-KP	20	16	110-23751	25	16	226-09101	12	28	226-54503	16	48
WS-0631510-KP	20	11	110-23801	25	21	226-09200	12	24	226-54552	16	47

From the library of: Diamond Needle Corp

NUMERICAL INDEX OF PARTS

索引

PART NO 品番	PAGE 頁	REF NO	PART NO 品番	PAGE 頁	REF NO	PART NO 品番	PAGE 頁	REF NO	PART NO 品番	PAGE 頁	REF NO
226-54602	16	49	226-93857	10	21						
226-54701	16	26	227-90000	18	25						
226-54800	16	14	227-90356	18	16						
226-54909	14	24	227-90455	19	4						
226-54958	14	21	227-90505	26	26						
226-55005	16	60	227-92251	18	31						
226-55104	16	22	227-92659	18	36						
226-55153	16	20	227-92758	19	7						
226-55302	16	11	227-92956	18	23						
226-55401	16	10	227-95108	18	2						
226-56003	20	27	227-95157	18	1						
226-56102	20	19	227-95207	18	3						
226-56201	20	18	227-95306	18	7						
226-56300	20	14	227-95355	18	6						
226-56409	20	13	227-95405	18	8						
226-57050	22	28	227-95504	18	20						
226-57100	22	18	227-95553	18	19						
226-57159	22	1	227-95702	18	22						
226-57209	22	6	227-95801	18	29						
226-57308	22	9	227-95900	18	12						
226-60609	2	37	227-96551	18	15						
226-80003	2	30	227-96700	19	6						
226-80250	2	18	227-96759	19	5						
226-80656	4	10	227-96809	19	2						
226-81001	6	11	227-96908	19	1						
226-81050	6	10	227-97559	19	8						
226-81100	6	1	227-97757	18	24						
226-81209	6	5									
226-81308	6	26									
226-81407	6	24									
226-81506	6	25									
226-81605	6	7									
226-81704	6	8									
226-81803	6	15									
226-82157	6	14									
226-83007	6	63									
226-83056	6	57									
226-83106	6	61									
226-83205	6	59									
226-83304	6	60									
226-83403	6	64									
226-83502	6	70									
226-83601	6	72									
226-83700	6	71									
226-83809	6	62									
226-83908	6	68									
226-84005	6	69									
226-84104	6	65									
226-84203	6	67									
226-84609	4	9									
226-84609	6	74									
226-84906	6	75									
226-85101	6	40									
226-85150	6	39									
226-85168	6	38									
226-85200	6	41									
226-85200	6	50									
226-85309	6	49									
226-85358	6	48									
226-85366	6	47									
226-85408	6	42									
226-85408	6	51									
226-85705	6	76									
226-85804	6	21									
226-85903	6	17									
226-86000	6	20									
226-86158	6	23									
226-86307	24	59									
226-87008	18	10									
226-87503	18	17									
226-88006	10	22									
226-88105	10	27									
226-88204	10	28									
226-88402	10	23									
226-88501	10	24									
226-92909	4	5									

From the library of: Diamond Needle Corp